

TOSHIBA

Unified Controller nv series™ *type1 light*

- TC-net is a registered trademark of Toshiba Infrastructure Systems & Solutions Corporation.
- Unified Controller nv series is a registered trademark of Toshiba Infrastructure Systems & Solutions Corporation.

Precautions

- Toshiba will bear no responsibility whatsoever for any damages arising from the use of or inability to use this product (including, but not limited to, loss of business profit, interruption of business, loss of business information, or other monetary losses).
- This product is not manufactured for the purpose of being applied to such systems as mentioned below which are directly related to human lives. In the event of the possibility of the product being used for such applications, please contact your Toshiba sales representative.
[Example]
 - Main unit control system of a nuclear power plant, safety protection system of a nuclear facility, or any other systems important for safety
 - Operation control system of mass transportation system or air traffic control system
 - Medical control system that has a bearing on human lives
- Use the product correctly after reading the instruction manual.
- This product cannot be used for application products whose manufacture and sale are prohibited by domestic and overseas laws and regulations.
- Export of this product or supply to overseas is restricted by the Foreign Exchange and Foreign Trade Law.
- This product is subject to the export control regulations of the US authorities, and permission from the US government may be necessary for export, depending on the export destination.
- The technical information contained herein is for the purpose of explaining the main operations and applications of the product.
- No guarantee or license is granted in regard to the intellectual property rights or any other rights of Toshiba or third parties arising from its use.
- The product names contained in this catalog may be trademarks of the companies concerned.

Toshiba Infrastructure Systems & Solutions Corporation

Industrial Systems & Instrumentation Sales Department
Industrial Systems Division
72-34 Horikawa-cho, Saiwai-ku, Kawasaki-shi, Kanagawa, 212-8585 Japan
Tel: +81-44-331-1694

© 2019 Toshiba Infrastructure Systems & Solutions Corporation

- The specifications and designs contained in this catalog are subject to change without notice for design change or other reasons.
- The information contained herein is valid as of March 2019. • Photographs are simulated images.

EG19035C
201905(TBLS)



Flexible Plant and Process Control

The type1 light controllers are 2nd generation V2000 CPU modules

The Unified Controller nv series™ type1 light controllers are available in a range of options for a variety of industrial and process control applications.

FLEXIBLE

World-standard High-speed I/O system

The type1 light employs the high-speed serial I/O system TC-net™ I/O for communication based on global-standard TCnet^{*1}. It is a highly flexible, remote I/O system suitable for connection to I/O in multiple platforms distributed in many locations.

*1: TCnet is one of the standards included in Real-Time Ethernet international standard IEC 61784-2/61158 advocated by Toshiba Corporation.

RELIABLE

Enhanced System Availability

Due to the critical nature of infrastructure facilities, industrial plants and process systems, stoppage may not be permissible even in the event of equipment breakdown. Toshiba uses high quality ICs and board level testing procedures available. For extremely critical systems, redundant configurations are available and recommended.

STANDARDIZATION

Innovating the Future of Design

The programming software complies with the international standard IEC 61131-3. It supports industry-standard IEC 61131-3 program languages. This ensures that program assets are reusable and design expertise can grow with system expansion.

MIGRATION

Existing Assets can be used in Future Control Systems

The type1 light controllers can directly replace the Integrated Controller V Series Model 2000 Sequence Control Module S2. The type1 light controllers can replace V2000 S2 systems because of program compatible. Of course it will also replace V2000 S2E & S2T systems with only program migration soon.





Application No.1 Water & Wastewater

[Application]: Water and wastewater control system

[Purpose]: ▶ Maintenance of water quality ▶ Surveillance of equipment operating status

[Merits of Toshiba Group system]:

- ▶ Flexible and scalable system architecture
- ▶ Mutual pump station surveillance using wide-area network

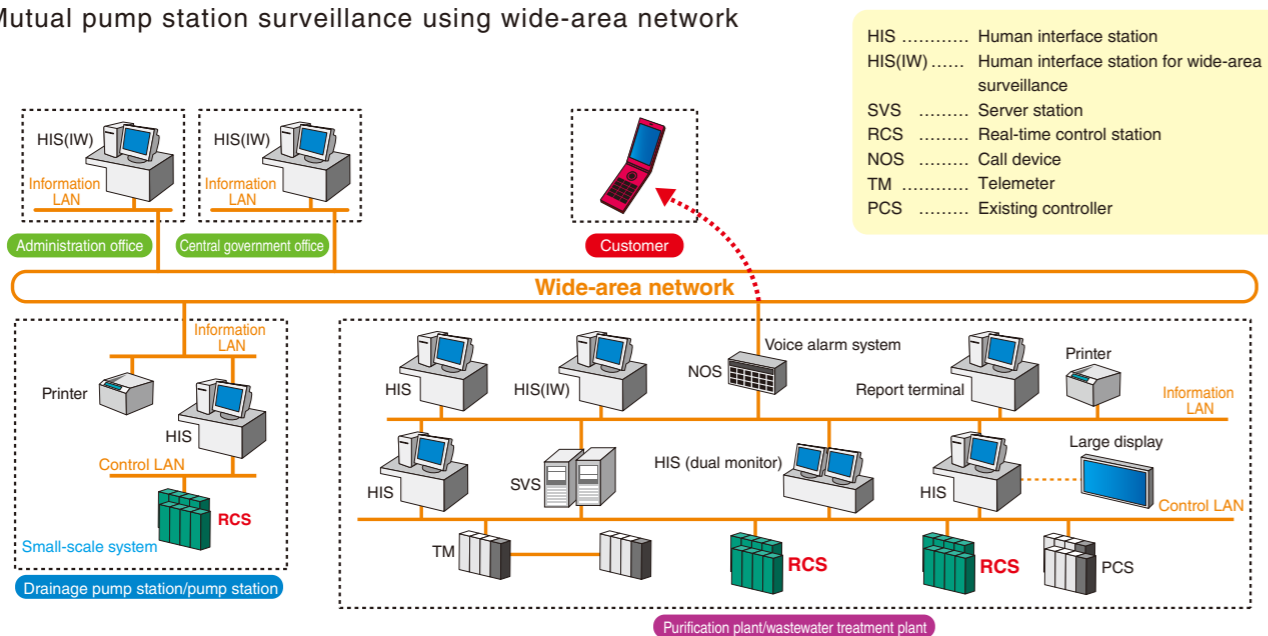

Application No.2 Oil & Gas

[Application]: Remote Pump Station Power & Control

[Purpose]: ▶ Control and monitoring of pumps, motors, drives, & other equipment

[Merits of Toshiba Group system]: ▶ Flexible, scalable Toshiba system configuration

- ▶ Fast, reliable fiber-optic loop
- Each drive is optically isolated
- One break in loop does not shutdown system
- Drive configuration & parameters available to PLC

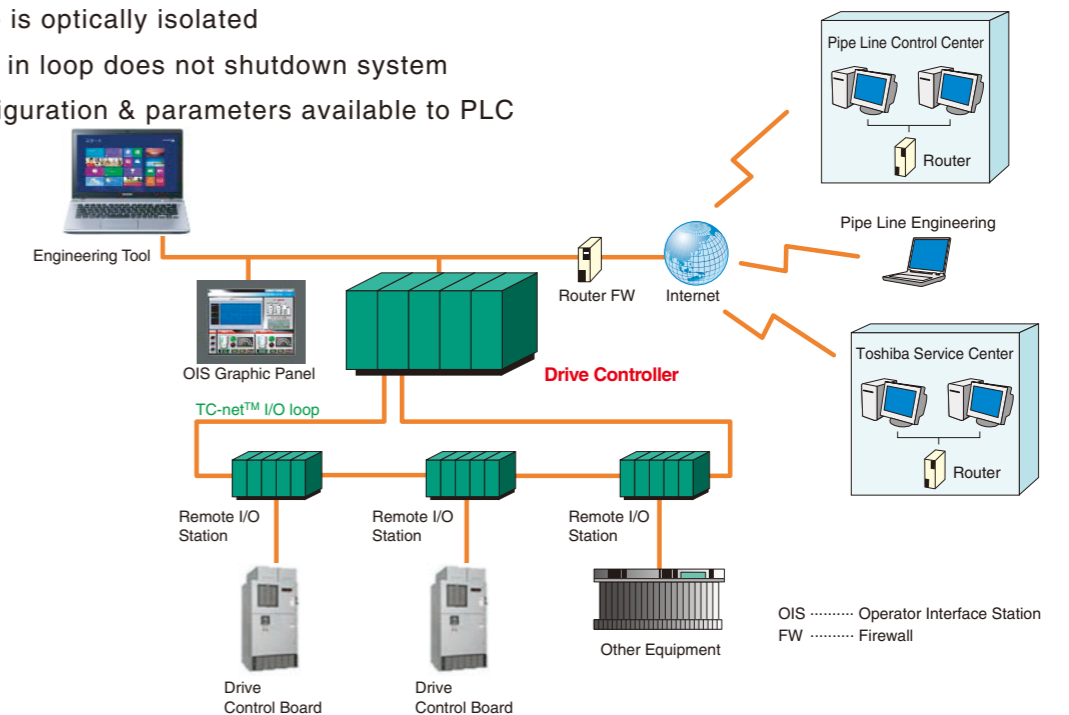



Application No.3

Transportation Infrastructure

[Application]: Remote tunnel surveillance control system

- [Purpose]:
- ▶ Tunnel brightness control
 - ▶ Emissions ventilation control
 - ▶ Emergency equipment control

[Merits of Toshiba Group system]:

- ▶ Collective surveillance of tunnels over a wide area
- ▶ Attainment of emission standards and efficient operation of ventilation fans

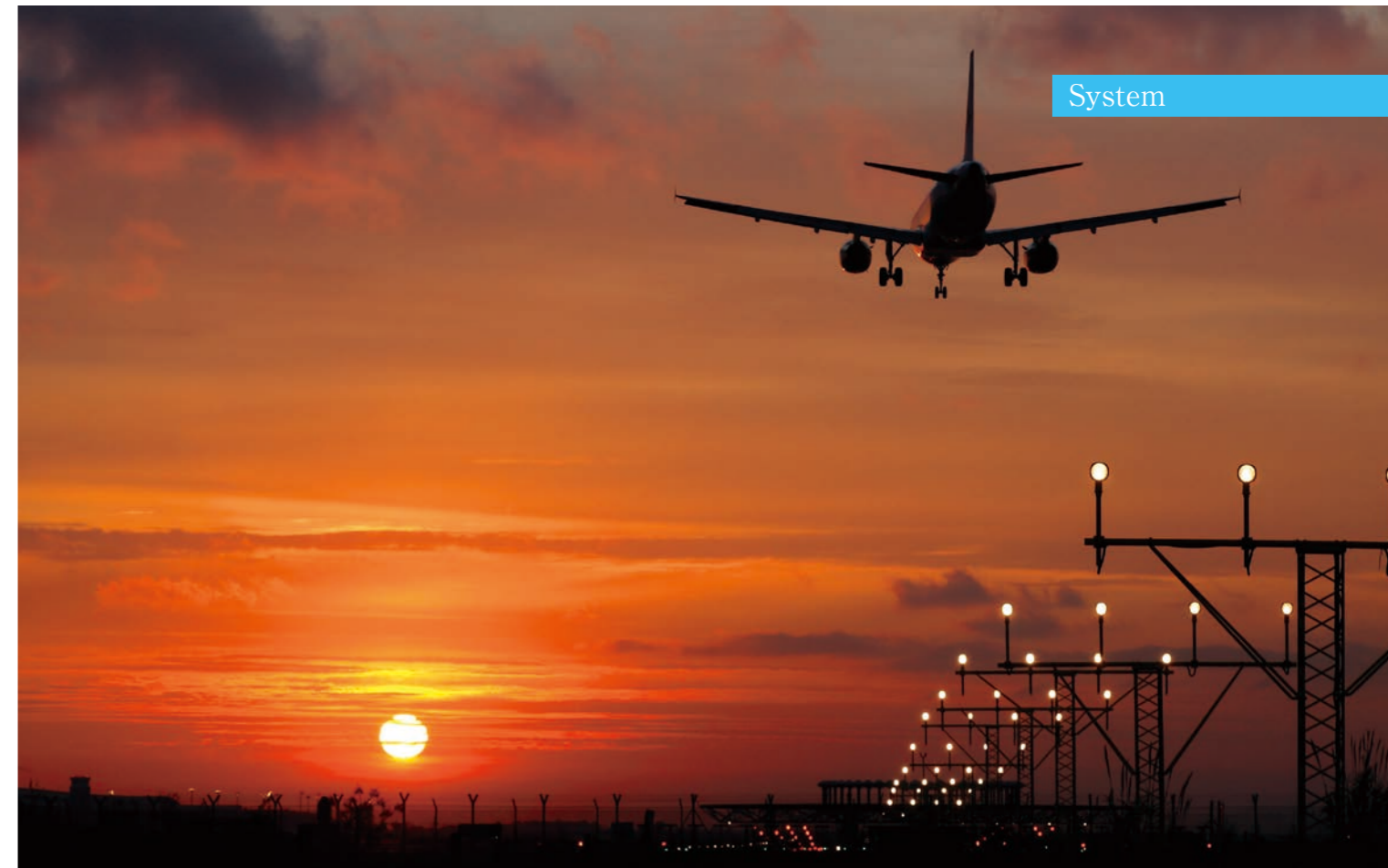
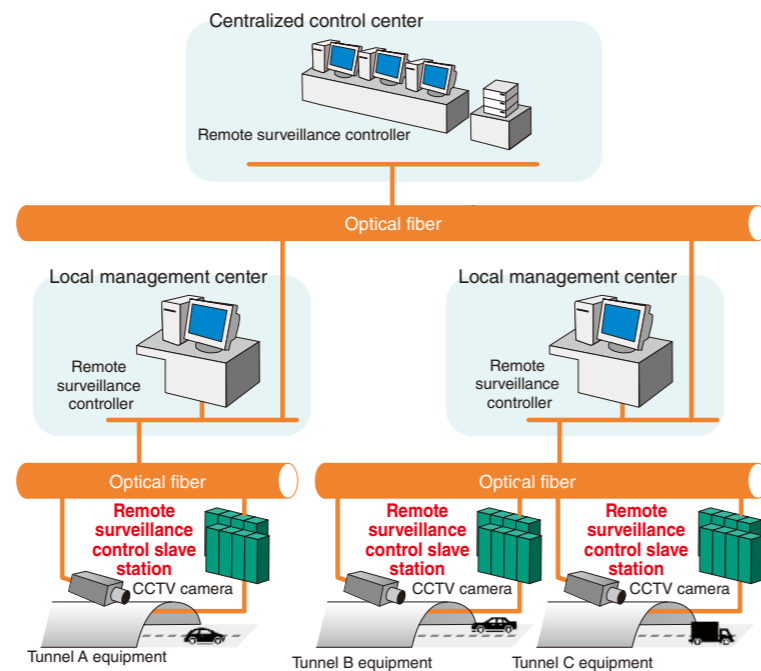

Application No.4

Aviation Systems

[Application]: Aeronautical ground light surveillance control system

- [Purpose]:
- ▶ High-speed light control
 - ▶ Operation and maintenance of power supply facilities for lights

[Merits of Toshiba Group system]:

- ▶ Turns lights on/off / Collectively controls light intensity and provides easy-to-see visual guidance for pilots
- ▶ High-speed control of input at control tower
- ▶ Enhanced reliability by transmission line and duplex processing unit

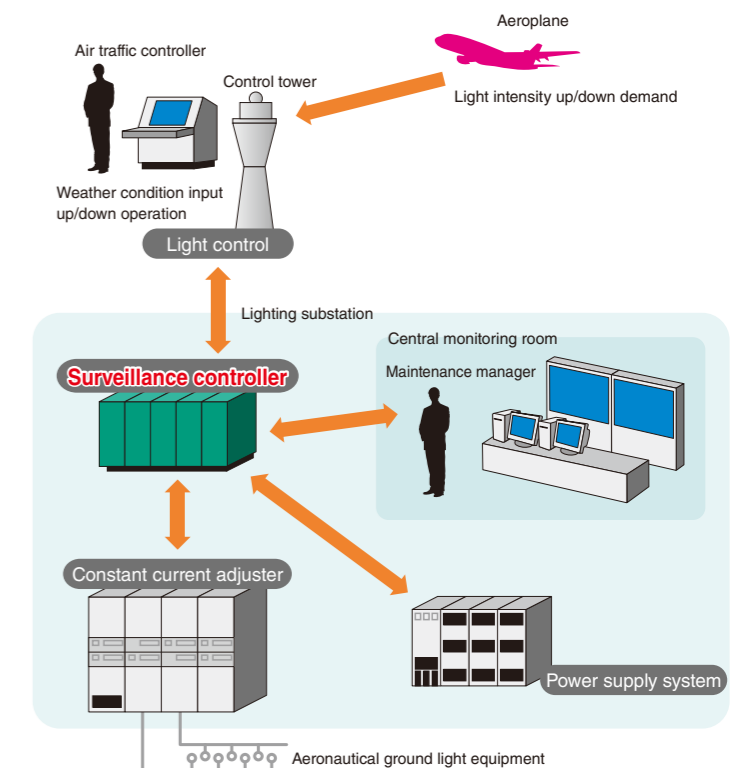



Application No.5

Power Generation

[Application]: Control processing system for dam management

- [Purpose]:
- ▶ Dam & basin catchment management
 - ▶ Flood control and other discharge operations

[Merits of Toshiba Group system]:

- ▶ Failsafe prevention of gate misoperation
- ▶ Stable operation by duplex collection system
- ▶ Motor-driven control by human operation or automatic command

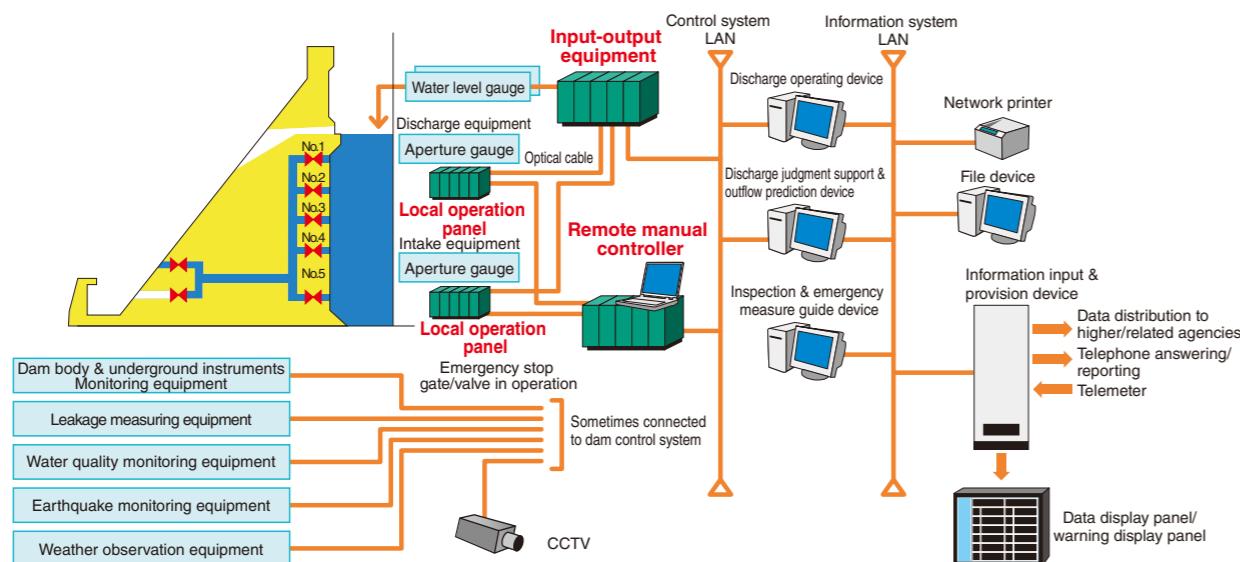

Application No.6

Material Handling

[Application]: Crane*1 drive control system

- [Purpose]:
- ▶ Motor-driven control by human operation or auto command
 - ▶ Crane operating status management and data collection

[Merits of Toshiba Group system]:

- ▶ Crane manoeuvrability, efficient operation, stable drive
- ▶ Visualization of operating status by IT/information collaboration
- ▶ Long-term use due to system reliability

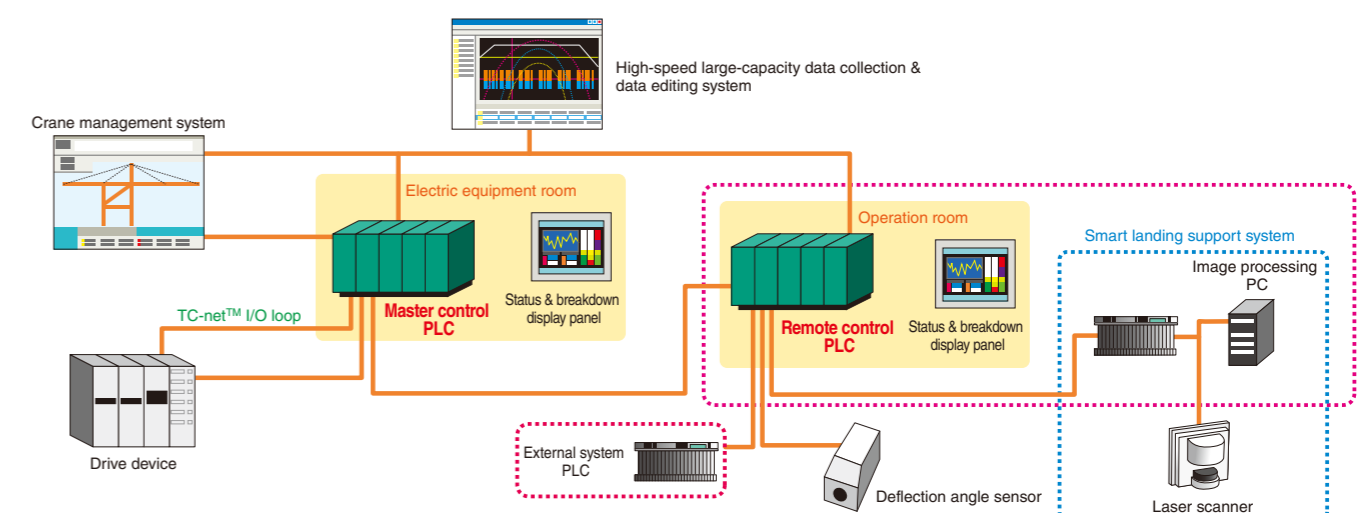

*1: Handling equipment including container cranes, overhead cranes in factories, equipment for shipbuilding, equipment for building construction, and unloaders

type1 light S

Standard Sequence Control Module

The type1 light S CPU mounts in a standard V2000 I/O rack (3 I/O, 5 I/O or 8 I/O racks are available). It can replace a S2E module. The type1 light S does not support racks with station bus, or I/O modules that require a station bus.

Compact CPU Module

The type1 light S CPU has both a RS485 port and an Ethernet port which supports Toshiba's ASCII computer link protocol. This allows connection by any HMI or SCADA software that has the Toshiba computer link driver.

Basic System Configuration

Local I/O Configuration

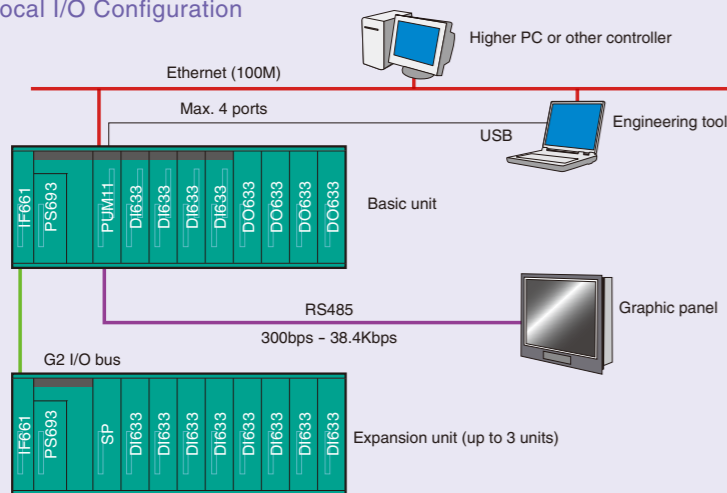

Local I/O unit

BU668	Basic base
PUM11	CPU module
IF661	G2 I/O interface
PS693	Power source unit
DI633	G2 I/O DI 16 points
DO633	G2 I/O DO 16 points
BU668	Expansion base

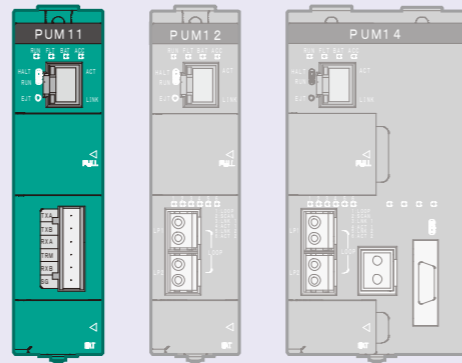

CPU module: PUM11
 Program capacity: 32K steps
 Number of I/O connections: Up to 32
 External I/F: Ethernet
 RS485 (computer link protocol)
 USB (for programming & monitoring)

type1 light H

High-performance Sequence Control Module

The Unified Controller nv series™ TC-net™ I/O is built-in to the type1 light H CPU. It can be applied to I/O systems to provide enhanced performance. The master station, built into the CPU module, enables direct connection of the TC-net™ I/O loop. A 4 km-long remote I/O system than can be installed at low cost. The connected I/O can be selected from Integrated Controller V2000 series I/O (G2 I/O) or Unified Controller nv series™ TC-net™ I/O.

Remote I/O System Configuration

TC-net™ I/O collects and controls remote field I/O in real time. The TC-net™ I/O is a high-speed, robust communications I/O system which uses a fiber optic cable which is highly resistance to electrical noise.

Basic System Configuration

Local I/O Configuration

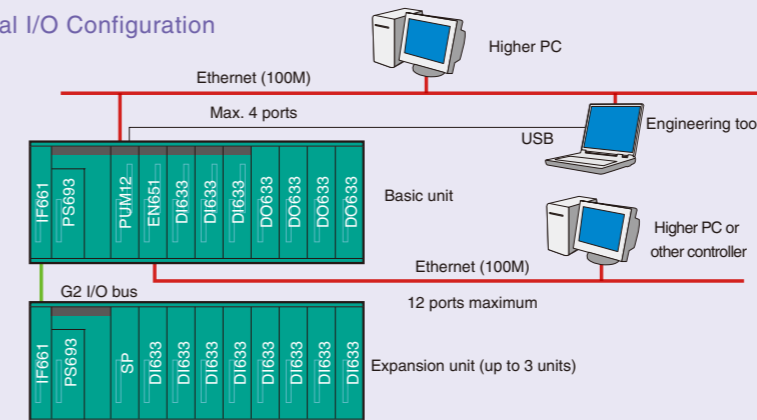

Local I/O

BU648E	Basic base
PUM12	CPU module
IF661	Expansion interface
PS693	Power source module
EN651	Ethernet 100M
DI633	G2 I/O DI 16 points
DO633	G2 I/O DO 16 points
BU668	Expansion base

Remote I/O Configuration

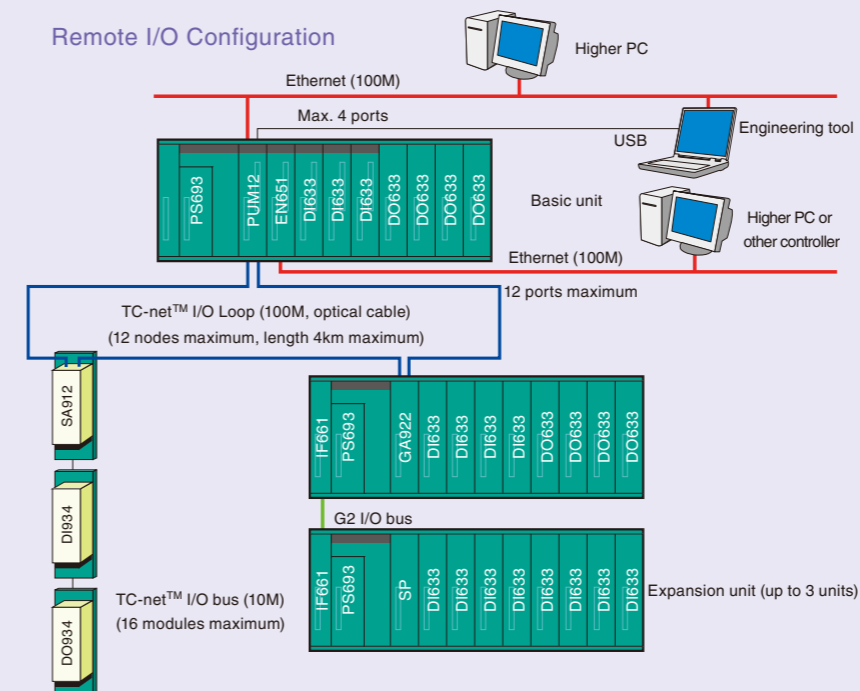

Remote I/O

BU648E	Basic base
PUM12	CPU module
IF661	Expansion interface
PS693	Power source module
EN651	Ethernet 100M
DI633	G2 I/O DI 16 points
DO633	G2 I/O DO 16 points
BU901	TC-net™ I/O adapter base
SA912	TC-net™ I/O adapter
BU905	TC-net™ I/O base
DI934	TC-net™ I/O DI 32 points
DO934	TC-net™ I/O DO 32 points
BU668	Expansion base
GA922	G2 I/O adapter

type1 light D

Redundant Sequence Control Module

The type1 light D CPU supports redundancy. Redundancy enables greater productivity by providing the highest system availability. With a program capacity of 128K steps and the ability to connect up to 192 I/O modules, the type1 light D is ideal for critical medium and large-scale systems. The module can also be used in a single module configuration.

High Performance and Critical System Reliability

Automatic switching to the secondary CPU occurs if a problem is detected in the primary CPU.

Duplex System Configuration

Local I/O Configuration

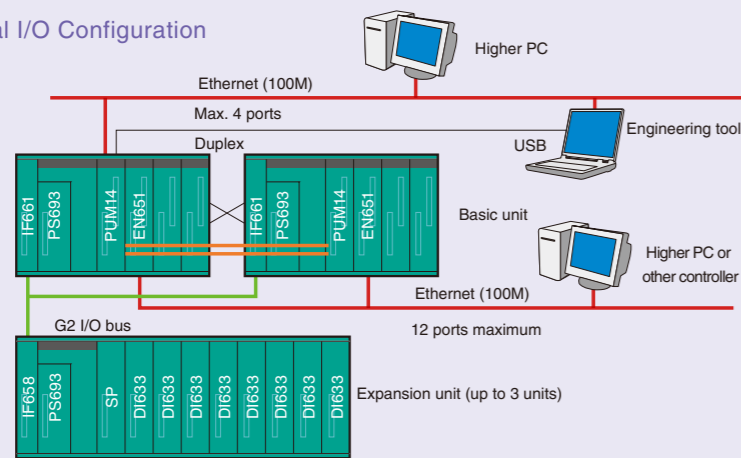

Local I/O	
BU643D	Basic base
PUM14	CPU module
IF661	Expansion interface
IF658	Expansion interface (2 ports)
PS693	Power source module
EN651	Ethernet 100M
BU668	Expansion base
DI633	G2 I/O DI 16 points
DO633	G2 I/O DO 16 points

Remote I/O Configuration

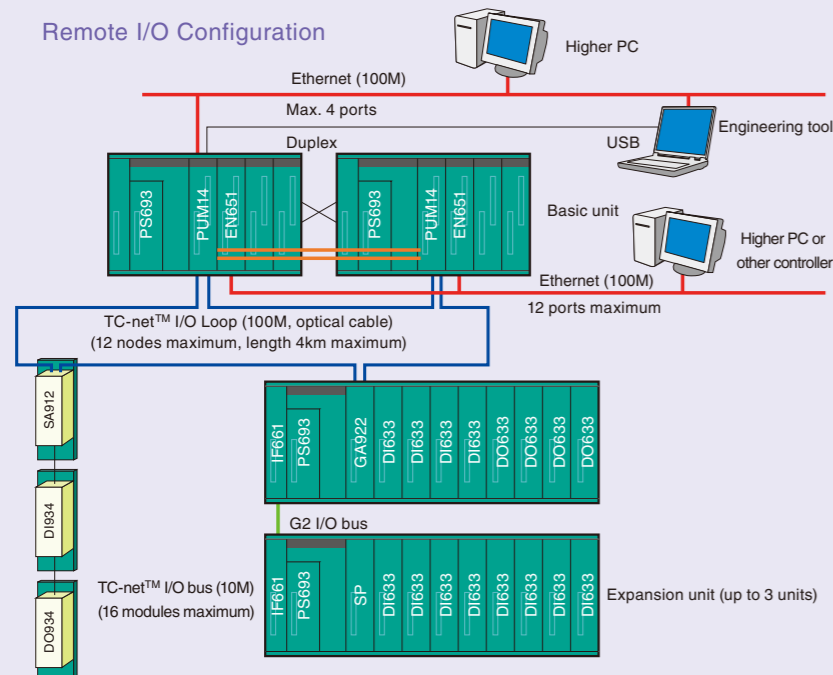

Remote I/O	
BU643D	Basic base
PUM14	CPU module
IF661	Expansion interface
PS693	Power source module
EN651	Ethernet 100M
BU668	Expansion base
GA922	G2 I/O adapter
DI633	G2 I/O DI 16 points
BU901	TC-net I/O adapter base
DO633	G2 I/O DO 16 points
SA912	TC-net I/O adapter
BU905	TC-net I/O base
DI934	TC-net I/O DI 32 points
DO934	TC-net I/O DO 32 points

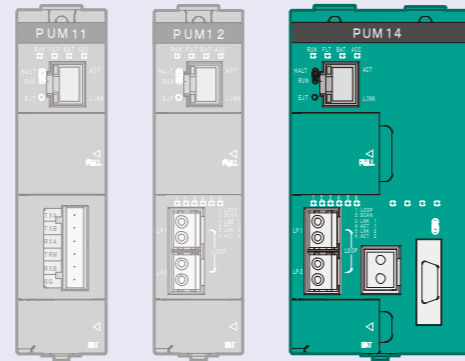

CPU module: PUM14
 Program capacity: 128K steps
 TC-net™ I/O Loop: 1 loop
 Number of TC-net™ I/O connections: Up to 192
 External I/F: Ethernet, USB (for programming & monitoring)

Equipment Configuration

Local I/O Configuration

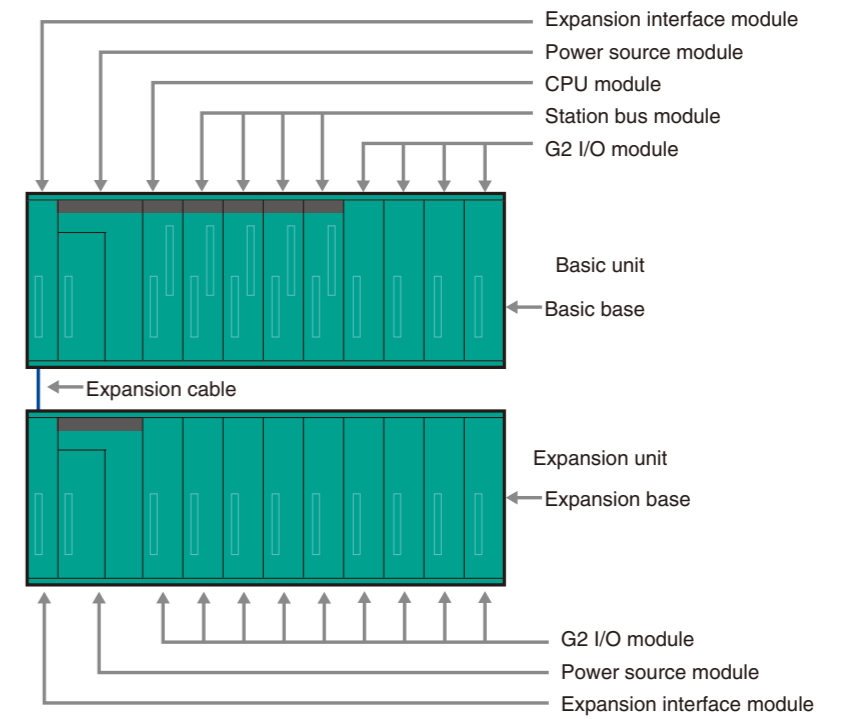

Remote I/O Configuration

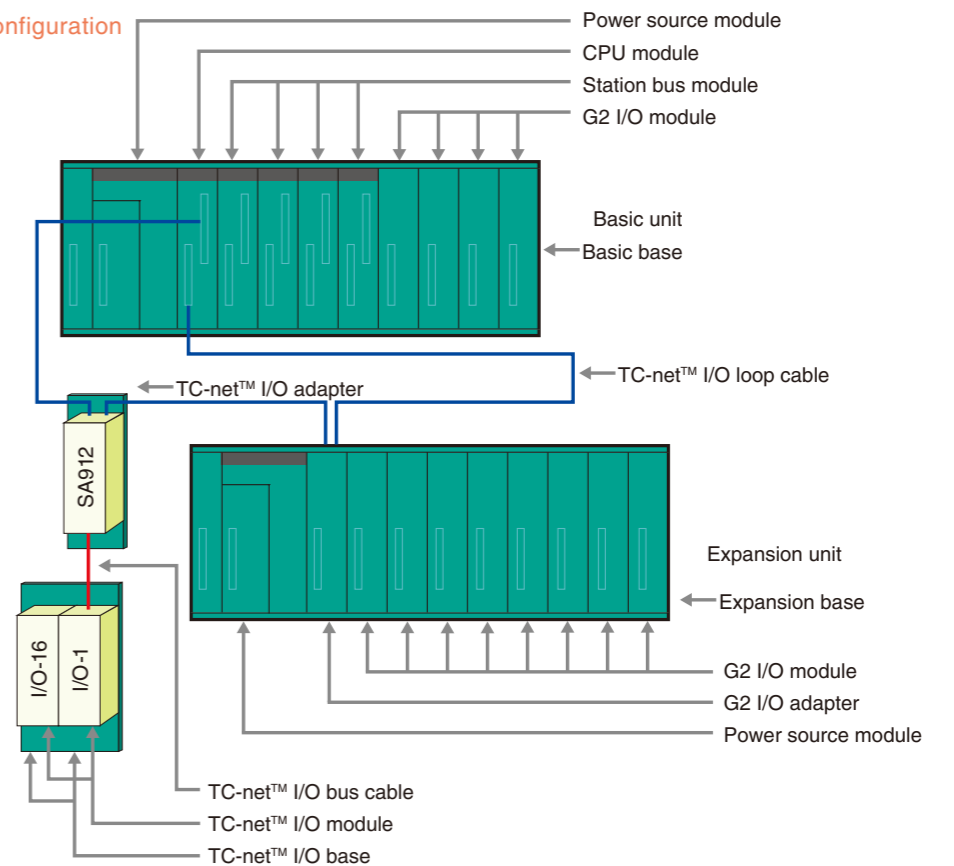

type1 light Support Software

Programming Software

Engineering Tool nV-Tool

The nV-Tool is a programming software that is uniformly used across all Toshiba's industrial and process controllers^(*). It is the only programming tool needed to fully develop, test and debug application programs. Its versatility, ease of use, and built-in library of pre tested application function blocks allows the programmer to quickly deploy application solutions. The CPU can store the complete program, with documentation, or just the run-time application.

(*1) Toshiba Integrated Controller V series, Toshiba Unified Controller nv series

IEC 61131-3 Programming Environment

The nV-Tool uses a full graphic editor to place, arrange and relocate symbols on the worksheet. It makes automatic connections, line crossings and groundings. The nV-Tool supports IEC 61131-3 compliant LD/FBD/SFC/ST languages. Multiple languages can be used on the same worksheet (block).



Trouble Shooting

A variety of features are available for maintaining and support of the type1 light program. The on-line graphic editor shows LD power flow, FB values, and SFC active steps. The Synchro Trend, I/O force and data monitor are also very useful in troubleshooting. An event log monitors and records every change in system status.



Custom Graphic Symbols

The nV-Tool has a symbol editor for creation of detailed graphic symbols unique to specific items of equipment or special functions. Function blocks can they be replaced with graphic symbols for easier visual comprehension of program action and flow. Examples of graphic symbols include: ASDs, Lead-Lag-Stand-by arrangements, Motor Starters, Valve Controllers, etc.

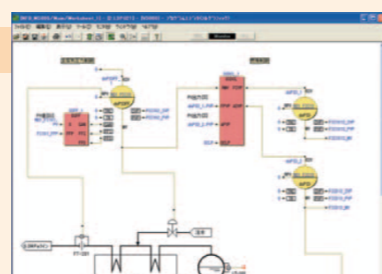

XML Import/Export

The XML file import/export function allows exchange of programs between different V Series/nv series controllers. A project can grow as need or split out into separate controllers if required. XML files are compliant with the industry-standard PLCopen XML Schema Ver. 1.0.

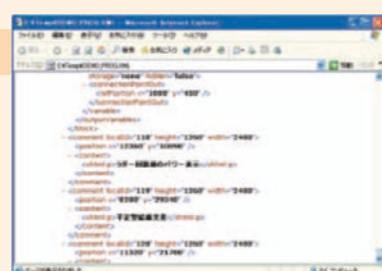

Add-in Software

Simulator (planned), remote engineering packages and other software ensure efficient programming, high quality and easy maintenance.

Total Support for System Engineering

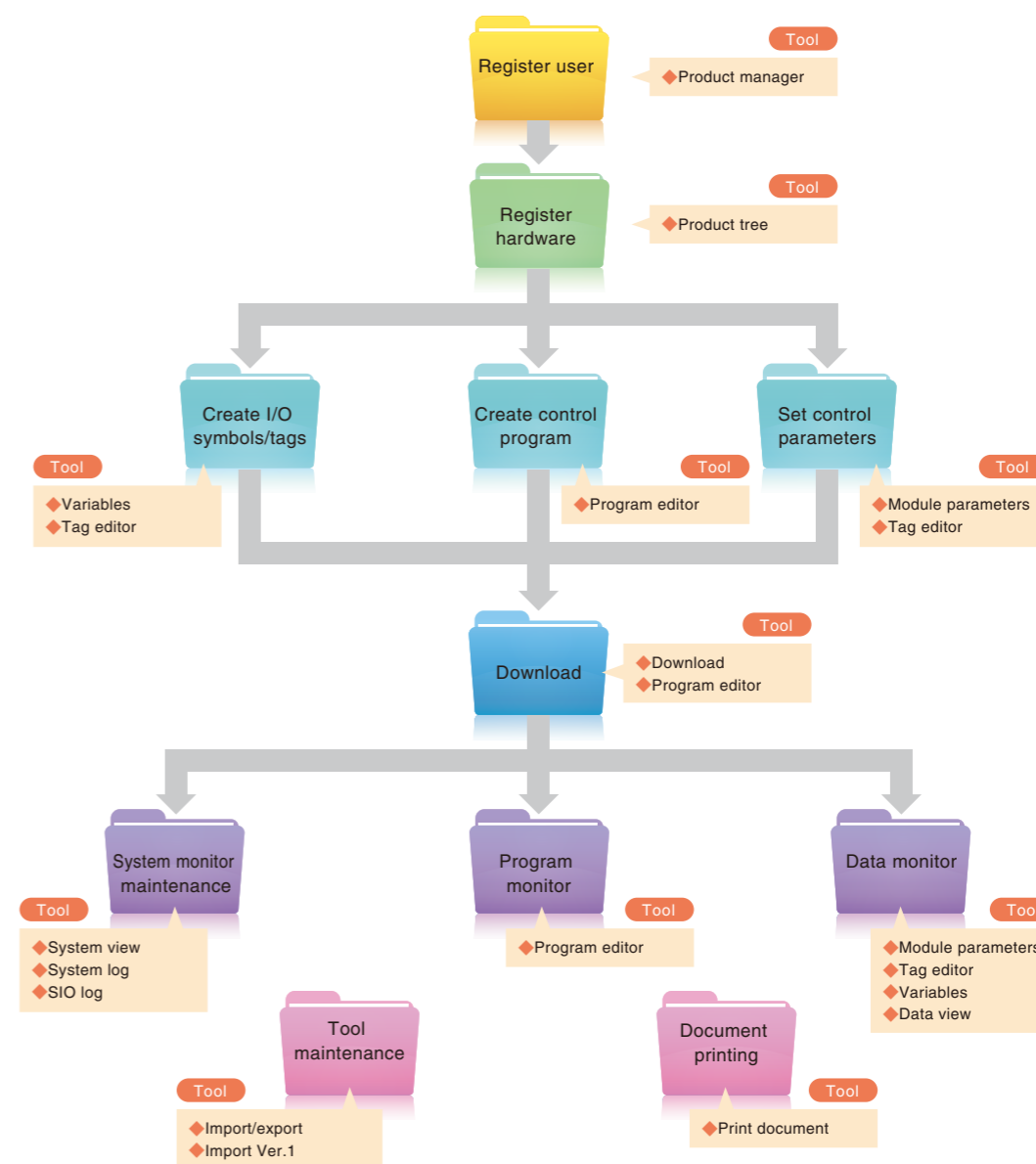

Example of tool screen

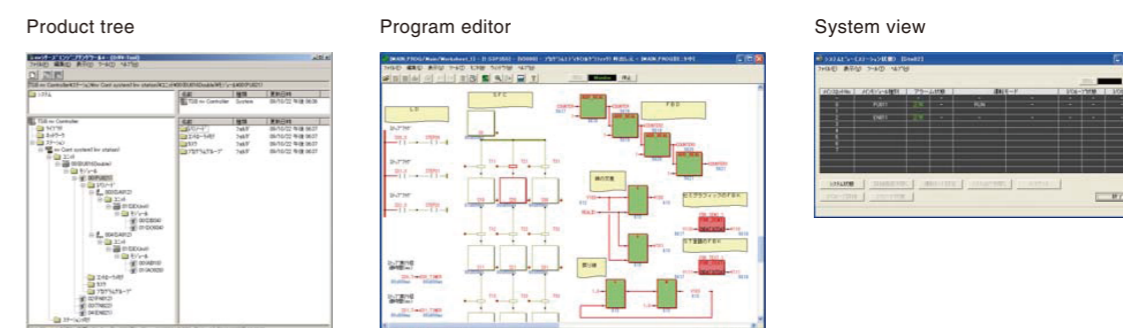

■ Environmental specifications

Item	Specifications
Operating ambient temperature	0 - 55°C (24-hour average temperature 40°C or less)
Storage temperature	-40~70°C ^{*1}
Relative humidity	5-95% RH (with no condensation)
Dust	0.3mg/m ³ (no conductive dust)
Pollution degree	2 or less IEC 61131-2/JIS B 3502
Corrosive gas	No corrosive gas shall be present ^{*2}
Vibration resistance	5<=f<8.4Hz: 3.5mm, 8.4<=f<150Hz: 9.8m/s ² (Compliant with IEC 60068-2-6 / JIS C 60068-2-6, test Fc)
Impact resistance	147m/s ² (Compliant with IEC 60068-2-27 /JIS C 60068-2-27, test Ea)
Noise resistance	Impulse noise (power line): 1500Vp-p, pulse width: 1μs , static electricity: 4KV, radiation field: 10V/m
Insulation resistance	DC500V mega 10MΩ or more ^{*3}
Withstand voltage	AC2000V per minute ^{*3}
Grounding	100Ω or less (type D grounding)
Cooling system	Natural cooling

- *1 For long-term storage, spare parts should be kept in a dark place away from high temperature and humidity. The temperature and humidity for storing products for long periods should be 0-40°C and 20-80% RH (with no condensation) and the rate of temperature change should be no higher than 10°C/h. The service life of batteries and power sources, in particular, may be affected by high ambient temperature. Store at room temperature (25°C) or below.
- *2 No materials containing silicon; hydrogen sulfide, sulfurous acid gas, chlorine gas, nitrogen oxide (Nox), sulfur oxide (Sox), ammonia, silicon gas, etc.
- *3 Power terminal - ground terminal

■ Function specifications

Item	Specifications				
	type1 light S	type1 light H	type1 light D		
Control system	Stored program cyclic scan system				
Processor	Control processor	32 bit general purpose processor			
	Language processor	Exclusive language processor (LP)			
Execution method	Scan method	Ultrafast scan	1 - 500ms (1ms unit)		
		High-speed scan	1 - 500ms (1ms unit)		
	Main scan	Floating scan	Selectable		
		Scheduled scan	1 - 1000ms (1ms unit)		
Input/output system		Batch input/output: Yes (only MS task synchronized), direct input/output: Yes			
Interruption	I/O	Number	8		
	Multiple interrupt function	I/O multiple interrupt	Not possible		
	Interrupt response		1ms or less		
Program type		EV/SS/IP/HS/MS			
Program capacity		32K steps	64K steps	128K steps	
Number of tasks/programs	EV	8 tasks, 1 program/task			
	SS	1 task, 1 program/task			
	IP	8 tasks, 1 program/task			
	HS	1 task, 128 programs/tasks			
	MS	1 task, 256 programs/tasks			
Data volume	Local/global variables		64KW	96KW	128KW
	Special register (S)		1KW		
	Data register (D)		8KW		
	Station global variables		-		
	I/O variables (IQ)		3KW	3KW	8KW
	Index register		8 types		

Number of timers		Arbitrary size setting function for user data domain			
I/O [G2 I/O]	Number of connections	System	1 system		
		Maximum number of units	4 units (1 basic + 3 expansion)		
		Maximum number of slots	32 slots	32 slots	31 slots (single) / 24 slots (dual)
	Batch input/output	I/O update time	22μs/W or less (at 64-point I/O, 4 consecutive accesses)		
		Transmission update time	22μs/W or less (at 64W consecutive accesses)		
	Direct input/output	Instruction time	10μs/W or less		
Transmission update time		15μs/W or less			
TC-net I/O Loop		-	1 loop (up to 12 nodes)	1 loop (up to 12 nodes)	
I/O [via TC-net I/O Loop]	Maximum number of G2 I/O points	-	12 nodes, 64 slots	12 nodes, 192 slots	
	Maximum number of G3 I/O points	-	1 node, 77 slots	1 node, 77 slots	
	Maximum number of TC-net I/O points	-	12 nodes, 64 slots	12 nodes, 192 slots	
Program languages		LD (ladder diagram), FBD (function block diagram), SFC (sequential function chart), ST (structured text)			
Execution speed	Bit	Contact	0.08μs	0.04μs	0.04μs
		Coil	0.16μs	0.08μs	0.08μs
	Integer	Transmission	0.08μs	0.04μs	0.04μs
		Calculation	0.08μs	0.04μs	0.04μs
		Multiplication	0.24μs	0.12μs	0.12μs
	Floating	Calculation	0.4μs	0.2μs	0.2μs
Multiplication		0.4μs	0.2μs	0.2μs	
System configuration		Single	Single	Single/dual	
Ethernet	Channel	1ch built-in (100Mbps)	1ch built-in, via external EN module (100Mbps)		
	Tool connection	Possible (built-in)	Possible (built-in/EN651A)		
	Computer link	Possible (built-in)	Possible (built-in/EN651A)		
	Socket communication	Possible (built-in)	Possible (built-in/EN651A, EN911)		
	PC link	Possible (built-in)	Possible (built-in/EN651A)		
RS485	Channel	1ch built-in (300bps - 38.4Kbps)	-	-	
	Tool connection	Impossible	-	-	
	Computer link	Possible	-	-	
	Free port	Impossible	-	-	
USB	Channel	1ch built-in			
	Tool connection	Possible			
	Computer link	Impossible			
	Free port	Impossible			
Support network	Station bus	-	Ethernet, TOSLINE-S20, TOSLINE-S20LP		
	G2 I/O bus	TOSLINE-S20, TOSLINE-F10, TC-net 100LP, FL-net, Profibus, DeviceNet			
	TC-net I/O	-	TC-net 100LP, FL-net, Profibus, MODBUS RTU, Ethernet		
RAS function	Diagnosis	Battery check, I/O non-sync, I/O parity check, I/O package check, language processor function check, unauthorized order detection, WDT, peripheral LSI check, etc.			
	Surveillance	Logs (error log, event log, transmission event log), program execution time measurement, program congestion detection			
	Debugging & maintenance	Program monitor, data tracing, input/output force			

For further details of our products, contact your Toshiba sales representative or visit the website below.
<http://www.toshiba.co.jp/sis/en/seigyo/nv/dl/index3.htm>

CPU module

Item	Order No.	Name	Overview
PUM11	HPUM11**S	type1 light S	Standard sequence control module
PUM12	HPUM12**S	type1 light H	High-performance sequence control module
PUM14	HPUM14**S	type1 light D	Redundant sequence control module

Basic base, expansion base

Item	Order No.	type1 light S	type1 light H	type1 light D	Name	Overview
BU643D	GBU643D*S	×	○	○*2	Basic base	3 G2 I/O slot 3 station bus slot
BU648E	GBU648E*S	×	○	○*2	Basic base	8 G2 I/O slot 4 station bus slot
BU664	GBU664**S	○	×*1	×*1	Basic base, expansion base	4 G2 I/O slot
BU666	GBU666**S	○	×*1	×*1	Basic base, expansion base	6 G2 I/O slot
BU668	GBU668**S	○	×*1	×*1	Basic base, expansion base	8 G2 I/O slot

*1 Cannot be used as a basic base, but can be used as an expansion base.

*2 G2 I/O can be used on the type1 light D only in single configuration.

Power source module

Item	Order No.	Rated input voltage	Permissible voltage range	Internal control power source	External control power source	Max. power
PS632	GPS632**S	DC24V	DC20.4~28.8V	5.0V-7.0A 3.3V-1.0A	None	35W or less
PS652	GPS652**S	DC100/110V	DC85~120V	5.0V-7.0A 3.3V-1.0A	None	35W or less
PS691	GPS691**S	AC100~120V AC200~240V	AC85~132V AC170~264V	5.0V-8.0A 3.3V-1.0A	None	43W or less
PS693	GPS693**S	AC100~240V	AC85~64V	5.0V-7.0A 3.3V-1.0A	DC24V(±10%)0.8A	35W or less

Expansion interface module

Item	Order No.	Name	Overview
IF658	GIF658**S	G2 I/O expansion interface	For duplication (expansion unit side)
IF661	GIF661**S	G2 I/O expansion interface	Basic unit, expansion unit

Expansion cable

Item	Order No.	Name	Overview
CS6R3	GCS6R3*CS	Standard expansion cable	0.3 m
CS6R5	GCS6R5*CS	Standard expansion cable	0.5 m
CS6R7	GCS6R7*CS	Standard expansion cable	0.7 m
CS6*1	GCS6*1*CS	Standard expansion cable	1.2 m

Dual tracking cable (for the type1 light D)

Item	Order No.	Name	Overview
CX701	GCX701*CS	Dual signal line cable	Standard (1 m)
CX702	GCX702*CS	Dual signal line cable	2 m
CX703	GCX703*CS	Dual signal line cable	3 m
CX704	GCX704*CS	Dual signal line cable	4 m
CX705	GCX705*CS	Dual signal line cable	5 m
CX706	GCX706*CS	Dual signal line cable	6 m
CZ701	HCZ701*CS	Dual data line cable	Standard (1 m)
CZ702	HCZ702*CS	Dual data line cable	2 m
CZ703	HCZ703*CS	Dual data line cable	3 m
CZ704	HCZ704*CS	Dual data line cable	4 m
CZ705	HCZ705*CS	Dual data line cable	5 m
CZ706	HCZ706*CS	Dual data line cable	6 m

Battery

Item	Order No.	Name	Overview
BTM12	HBTM12*AS	Lithium battery	3.0 V-1000 mAh

Engineering tool

Item	Order No.	Name	Overview
HET81J4	HET81J4SS	nV-Tool4	Japanese stand-alone version
HET82J4	HET82J4SS	nV-Tool4	Japanese client server version
HET81E4	HET81E4SS	nV-Tool4	English stand-alone version
HET82E4	HET82E4SS	nV-Tool4	English client server version
HET81C4*1	HET81C4SS	nV-Tool4	Chinese stand-alone version

*1 nV-Tool4 (Chinese) is under development as of April 2014. For further details, contact your Toshiba sales representative.

Station bus module ○: Usable ×: Unusable

Item	Order No.	type1 light S	type1 light H	type1 light D	Specifications
CF612	GCF612**S	×	○*3	○*2*3	General-purpose communication interface module RS232C, RS485, 2ch, ASCII no control sequence
EN611	GEN611**S	×	○*1	○*1	Ethernet, 10 Base 5, single bus
EN631	GEN631**S	×	○*1	○*1	Ethernet, 10 Base 2, single bus
EN651A	GEN651A**S	×	○	○	Ethernet, 10 Base T, single bus
SN625	GSN625**S	×	○*1	○*1*2	TOSLINE-S20 coaxial bus
SN626	GSN626**S	×	○*1	○*1*2	TOSLINE-S20 optical bus
SN627	GSN627**S	×	○*1	○*1*2	TOSLINE-S20 optical loop

*1 These products are listed only to show the compatibility with predecessor models. Their sales have already been discontinued.

*2 Can be used only in single configuration.

*3 Functions are restricted.

■ G2 I/O module digital input/output ○: Usable ×: Unusable

Item	Order No.	type1 light S	type1 light H	type1 light D	Specifications
AC663	GAC663**S	○	○	○	AC100-240V triac output module, 0.5A/point, 12 points
CD633	GCD633**S	○*1	○*1	○*1	DC/AC12-24V input module with status change detection function, 8mA (at DC24V), 16 points
DI632D	GDI632D*S	○	○	○	DC/AC12-24V input module, 8mA (at DC24V), 8 points, stand-alone/COM
DI633	GDI633**S	○	○	○	DC/AC12-24V input module, 8mA (at DC24V), 16 points
DI634	GDI634**S	○	○	○	DC24V input module, 4mA (at DC24V), 32 points
DI635	GDI635**S	○	○	○	DC24V input module, 4mA (at DC24V), 64 points
DI635H	GDI635H*S	○	○	○	DC24V input module, 4mA (at DC24V), 64 points, high-speed input
DI653	GDI653**S	○	○	○	DC100-110V input module, 3mA (at DC100V), 16 points
DO633	GDO633**S	○	○	○	DC5-24V transistor output module, 1A/point (12/24V), 16 points (sink type)
DO633P	GDO633P*S	○	○	○	DC12-24V transistor output module, 1A/point (12/24V), 16 points (source type)
DO634	GDO634**S	○	○	○	DC5-24V transistor output module, 0.1A/point (12/24V), 32 points (sink type)
DO635	GDO635**S	○	○	○	DC5-24V transistor output module, 0.1A/point (12/24V), 64 points (sink type)
IN653	GIN653**S	○	○	○	AC100-120V input module, 7mA (at AC100V), 16 points
IN663	GIN663**S	○	○	○	AC200-240V input module, 6mA (at AC200V), 16 points
RO662S	GRO662S*S	○	○	○	DC24V, AC240V, contact output module 2A/point (12/24A), 8 points standalone/COM
RO663	GRO663**S	○	○	○	DC24V, AC240V, contact output module 2A/point (12/24V), 16 points

*1 Interrupt function can be used only when connected to a basic base.

■ G2 I/O module analog input/output ○: Usable ×: Unusable

Item	Order No.	type1 light S	type1 light H	type1 light D	Specifications
AD624	GAD624**S	○	○	○	Analog input module (12 bit), 1-5V, 4-20mA, 4 ch, 2ms/4ch
AD624L	GAD624L*S	○	○	○	Analog input module (8 bit), 1-5V, 4-20mA, 4 ch, 1ms/4ch
AD628S	GAD628S*S	○	○	○	Analog input module (12 bit), 0-5V, 0-20mA, 8 ch (isolated), 2ms/8ch
AD634L	GAD634L*S	○	○	○	Analog input module (8 bit), 0-10V, 4 ch, 1ms/4ch
AD638S	GAD638S*S	○	○	○	Analog input module (12 bit), +/-10V, 8 ch (isolated), 2ms/8ch
AD668	GAD668**S	○	○	○	Analog input module (16 bit), -5-5V, -10-10V, 0-5V, 0-10V, 1-5V, 0-20mA, 4-20mA, 8 ch, 1ms/1ch
AD674	GAD674**S	○	○	○	Analog input module (12 bit), -10-10V, 4 ch, 2ms/4ch
DA622	GDA622**S	○	○	○	Analog output module (12 bit), 1-5V, 4-20mA, 2 ch, 1ms/2ch
DA622L	GDA622L*S	○	○	○	Analog output module (8 bit), 1-5V, 4-20mA, 2 ch, 1ms/2ch
DA624S	GDA624S*S	○	○	○	Analog output module (16 bit), 0-20mA, 4 ch (isolated), 1ms/4ch
DA664	GDA664**S	○	○	○	Analog output module (16 bit), -5-5V, -10-10V, 0-5V, 0-10V, 1-5V, 0-20mA, 4-20mA, 4 ch, 1ms/1ch
DA672	GDA672**S	○	○	○	Analog input module (12 bit), -10-10V, 2 ch, 1ms/2ch
RT614	GRT614**S	○	○	○	Resistance temperature detector input module (12 bit), Pt100 (3-wire), 4ch, 200ms/4ch
TC618	GTC618**S	○	○	○	Thermocouple input module (16 bit) TC K, J, E, 100mV, 7ch (1 ch for CJC), 8ch (100mV), 1ms/1ch

■ G2 I/O module pulse input ○: Usable ×: Unusable

Item	Order No.	type1 light S	type1 light H	type1 light D	Specifications
PI632	GPI632**S	○*1	○*1	○*1	Pulse input module 5/12/24V, max. 100kpps (except block pulse), max. 50kpps (block pulse), 24 bit binary, 2ch
PI672	GPI672**S	○*1	○*1	○*1	Pulse input module RS422, max. 100kpps (except block pulse), max. 50kpps (block pulse), 24 bit binary, 2ch

*1 Interrupt function can be used only when connected to a basic base.

■ G2 I/O module network ○: Usable ×: Unusable

Item	Order No.	type1 light S	type1 light H	type1 light D	Specifications
CF611	GCF611**S	○	○	○	General-purpose communication module, RS232C 1 port, ASCII no control sequence
DN611A	GDN611A*S	○	○	○	DeviceNet scanner
FL611	GFL611**S	○*1	○*1	○*1	FL-net controller station (Ver. 1.0) 10Mbps
FL612	GFL612**S	○*1	○*1	○*1	FL-net controller station (Ver. 2.0) 10Mbps
FL622	GFL622**S	○	○	○	FL-net controller station (Ver. 3.0.1, Class 1) 100Mbps
FL654	GFL654**S	○	○	○	FL-net compatible remote I/O station (Ver. 2.0)
PF611	GPF611**S	○	○	○	PROFIBUS master (DP-V0)
PF612	GPF612**S	○	○	○	PROFIBUS slave (DP-V0)
SN621	GSN621**S	○*1	○*1	○*1	TOSLINE-S20 coaxial bus
SN622	GSN622**S	○*1	○*1	○*1	TOSLINE-S20 optical bus
TN623	HTN623**S	○	○	○	TC-net 100 LP interface (optical loop)
UN611	GUN611**S	○	○	○	TOSLINE-F10 master station
UN612	GUN612**S	○	○	○	TOSLINE-F10 remote station

*1 These products are listed only to show the compatibility with predecessor models. Their sales have already been discontinued.

■ TC-net I/O adapter ○: Usable ×: Unusable

Item	Order No.	type1 light S	type1 light H	type1 light D	Specifications
GA922	HGA922**S	×	○	○	TC-net I/O loop (optical loop) ->G2 I/O adapter
PA912	HPA912**S	×	○	○	TC-net I/O loop (optical loop) ->PROFIBUS master (DP-V0)
SA912	HSA912**S	×	○	○	TC-net I/O loop (optical loop) ->TC-net I/O bus adapter

■ TC-net I/O loop cable ○: Usable ×: Unusable

Item	Order No.	type1 light S	type1 light H	type1 light D	Specifications
CM901P	HCM901P	×	○	○	1m, TC-net I/O loop cable
CM903P	HCM903P	×	○	○	3m, TC-net I/O loop cable
CM905P	HCM905P	×	○	○	5m, TC-net I/O loop cable
CM907P	HCM907P	×	○	○	7m, TC-net I/O loop cable
CM910P	HCM910P	×	○	○	10m, TC-net I/O loop cable

TC-net I/O base ○: Usable x: Unusable

Item	Order No.	type1 light S	type1 light H	type1 light D	Specifications
BU901	HBU901**S	x	○	○	TC-net I/O adapter base
BU902A	HBU902A*S	x	○	○	TC-net I/O base with ordinary I/O terminal block
BU903A	HBU903A*S	x	○	○	TC-net I/O base with analog input/output terminal block
BU904A	HBU904A*S	x	○	○	TC-net I/O base with analog input (TC) terminal block
BU905	HBU905**S	x	○	○	TC-net I/O base with digital input/output (64 point) connector
BU906A	HBU906A*S	x	○	○	TC-net I/O base with digital power (large current, high voltage) input/output terminal block

*1 The BU901 comes with two TR901 (terminal connectors) as standard. Other bases come with one CN9C3 (TC-net I/O bus cable) as standard.

TC-net I/O bus-related equipment ○: Usable x: Unusable

Item	Order No.	type1 light S	type1 light H	type1 light D	Specifications
TR901	HTR901**S	x	○	○	Terminal connector for TC-net I/O adapter
CN9C3	HCN9C3	x	○	○	TC-net I/O bus coupling cable (cable length: 3cm)
CN9C9	HCN9C9	x	○	○	TC-net I/O bus connection cable (cable length: 9cm)
CN9R5	HCN9R5	x	○	○	TC-net I/O bus crossover cable (cable length: 0.5m)
CN910S	HCN910S	x	○	○	TC-net I/O bus crossover cable (cable length: 1m)
CN920S	HCN920S	x	○	○	TC-net I/O bus extension cable (cable length: 2m)
CN940S	HCN940S	x	○	○	TC-net I/O bus extension cable (cable length: 4m)

TC-net I/O module digital input/output ○: Usable x: Unusable

Item	Order No.	type1 light S	type1 light H	type1 light D	Specifications
AC963	HAC963**S	x	○	○	AC100-240V triac output module, 2A/point, 16 points (2 points/COM)
DI934	HDI934**S	x	○	○	Digital input module DC24V, 5.2mA (at DC24V), 32 points (16 points/COM)
DI934S	HDI934S*S	x	○	○	Digital input module DC24V, 5.2mA (at DC24V), 32 points (isolated)
DI935	HDI935**S	x	○	○	Digital input module DC24V, 4mA (at DC24V), 64 points (16 points/COM)
DI936	HDI936**S	x	○	○	DC12-24V digital input module, 9.4mA (at DC24V), 16 points (isolated)
DI937	HDI937**S	x	○	○	DC12-24V digital input module, 9.6mA (at DC24V), 16 points (16 points/COM)
DI944	HDI944**S	x	○	○	Digital input module DC48V, 2.6mA (at DC48V), 32 points (16 points/COM)
DO934	HDO934**S	x	○	○	DC12-24V digital output module, 100mA/point, 32 points (16 points/COM)
DO935	HDO935**S	x	○	○	DC24V digital output module, 50mA/point, 64 points (16 points/COM)
DO936	HDO936**S	x	○	○	DC12-24V digital output module, 2A/point, 16 points (isolated)
IN956	HIN956**S	x	○	○	AC/DC100-120V digital input module, 15mA (at AC100V), 2.3mA (at DC110V), 16 points (isolated)
IN966	HIN966**S	x	○	○	AC/DC200-240V digital input module, 10mA (at AC200V), 16 points (isolated)
RO966	HRO966**S	x	○	○	AC100-240V/DC24V isolated contact, 2A/point, 16 points (isolated), relay contact

TC-net I/O module analog input/output ○: Usable x: Unusable

Item	Order No.	type1 light S	type1 light H	type1 light D	Specifications
AI914	HAI914**S	x	○	○	0-5V analog input, 4ch (isolated), 0-16000 counts, 1ms/4ch
AI918	HAI918**S	x	○	○	0-5V analog input, 8ch (isolated), 0-64000 counts, 10ms/8ch
AI918F	HAI918F*S	x	○	○	0-5V analog input, 8ch (isolated), 0-64000 counts, 10ms/8ch (High resolution)
AI919	HAI919**S	x	○	○	0-5V analog input, 16ch, 0-64000 counts, 50ms/16ch
AI928	HAI928**S	x	○	○	0-20mA analog input, 8ch (isolated), 0-64000 counts, 0.5ms/8ch
AI929D	HAI929D*S	x	○	○	0-20mA analog input, 16ch, 0-64000 counts, 50ms/16ch
AO928	HAO928**S	x	○	○	0-20mA analog output, 8ch (isolated), 0-64000 counts, 1ms/8ch
AO928F	HAO928F*S	x	○	○	0-20mA analog output, 8ch (isolated), 0-64000 counts, 1ms/8ch (High resolution)
RT918	HRT918**S	x	○	○	Pt100, JPt100, 8ch, 0-32000 counts, 800ms/8ch (isolated)
RT918C	HRT918C*S	x	○	○	Pt100, JPt100, 8ch, 0-32000 counts, 800ms/8ch
TC919	HTC919**S	x	○	○	TC B, R, S, J, K, T, E, 16ch (isolated), 0-32000 counts, 800ms/16ch

TC-net I/O module pulse input ○: Usable x: Unusable

Item	Order No.	type1 light S	type1 light H	type1 light D	Specifications
PI918	HPI918**S	x	○	○	12-24V, 50Hz/50KHz, 15 bit up-counter, 8ch
PI924	HPI924**S	x	○	○	12-24V, 50Hz/50KHz, 16 bit up/down counter, 4ch

TC-net I/O module network ○: Usable x: Unusable

Item	Order No.	type1 light S	type1 light H	type1 light D	Specifications
EN911	HEN911**S	x	○	○	Ethernet 100Base-T
FL911	HFL911**S	x	○	○	FL-net controller station (Ver. 2.0) 100Mbps
IA931	HIA931**S	x	○	○	G3 I/O adapter
IS911	HIS911**S	x	○	○	RS232C/485 SYSMAC/MELSEC serial communication
MD911	HMD911**S	x	○	○	MODBUS/RTU master/slave
TN923	HTN923**S	x	○	○	TC-net 100 LP interface (optical loop)

Other companies' related equipment ○: Usable x: Unusable

Item	type1 light S	type1 light H	type1 light D	Specifications
Device Explorer OPC server*1	○	○	○	Unified Controller nv series OPC server (computer link-compliant)

*1 For inquiries concerning this product, please contact the address below.

[Inquiries] Takebishi Corporation

[Customer Support] +81-75-325-2261

[Hours] 9:00-17:00 (except Saturday, Sunday, public holidays)

[E-mail] fa-support@takebishi.co.jp

[Website] http://www.faweb.net

type1 light - Full view -

■ CPU module (PUM11/PUM12) (Unit:mm)

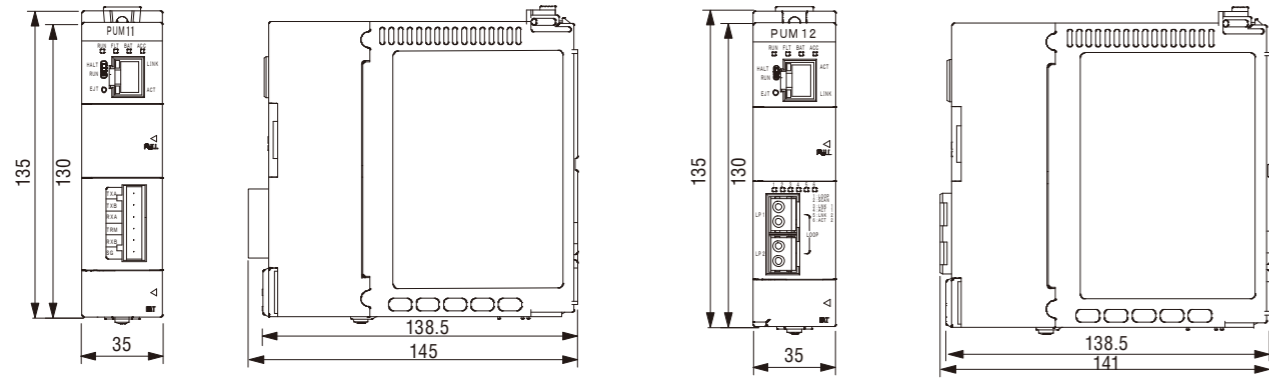

■ Basic base unit (BU648E) (Unit:mm)

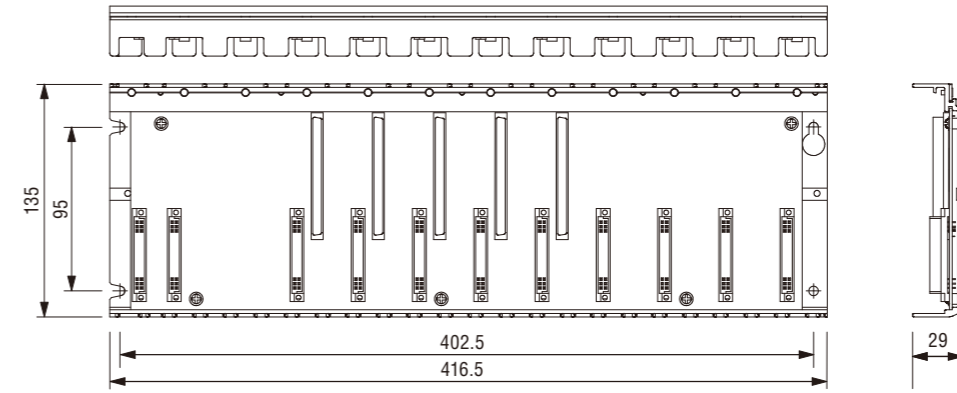

■ CPU module (PUM14) (Unit:mm)

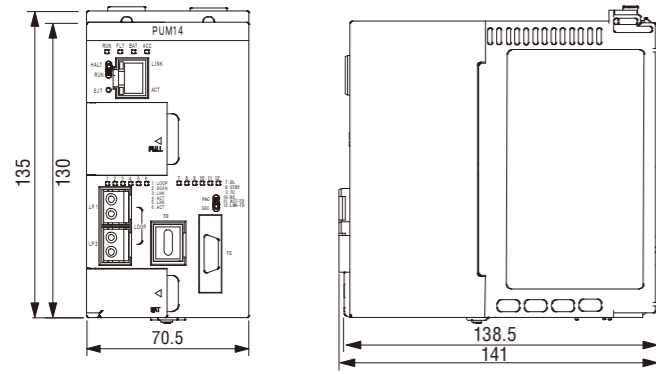

■ Basic/expansion base unit (BU664) (Unit:mm)

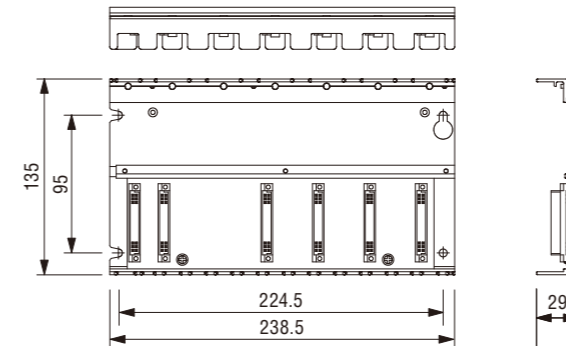

■ Basic base unit (BU643D) (Unit:mm)

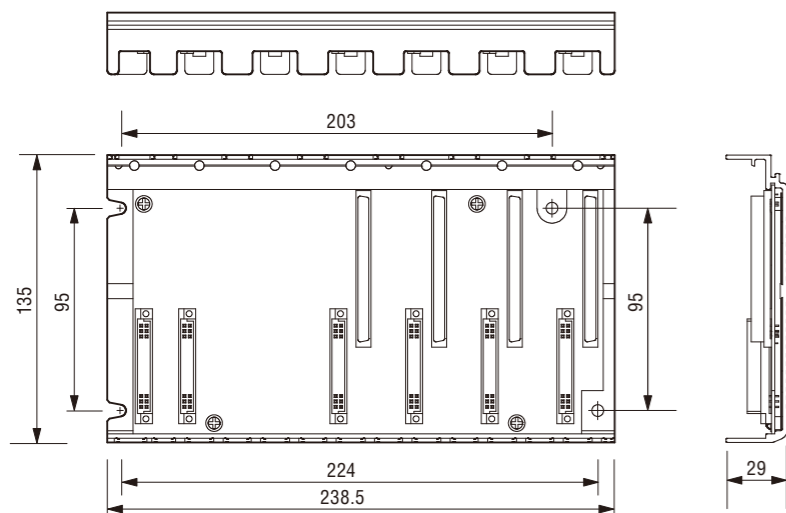

■ Basic/expansion base unit (BU666) (Unit:mm)

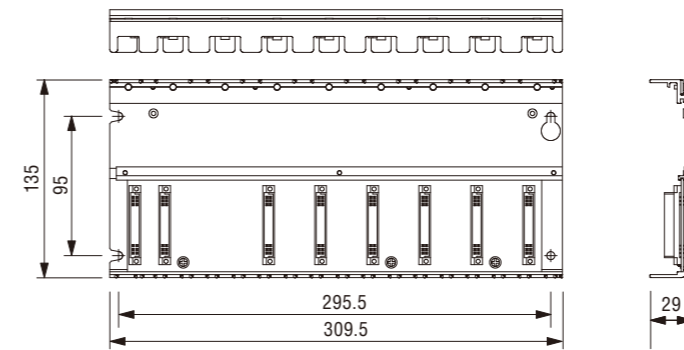

■ Basic/expansion base unit (BU668) (Unit:mm)

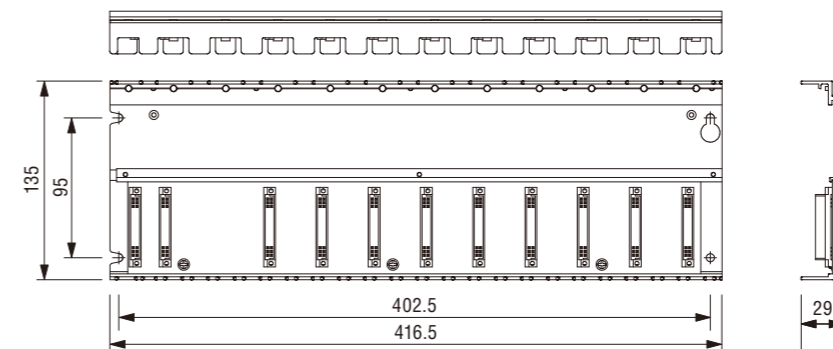

■ Power source module (Unit:mm)

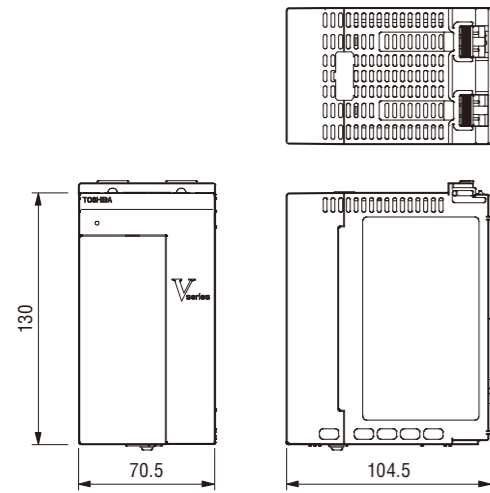

■ TC-net I/O module (Unit:mm)

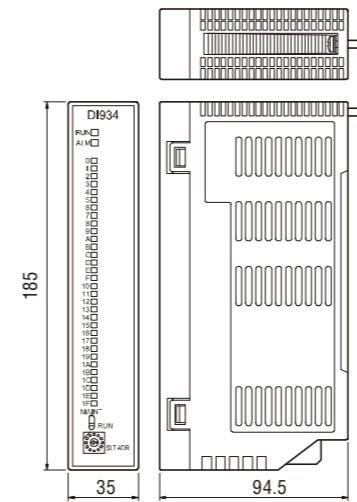

■ TC-net I/O adapter (Unit:mm)

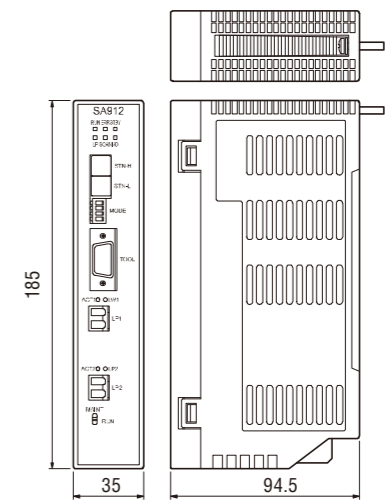

■ G2 I/O module Connector type (Unit:mm)

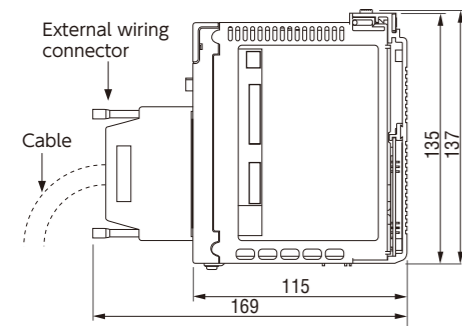

■ G2 I/O module terminal block type (Unit:mm)

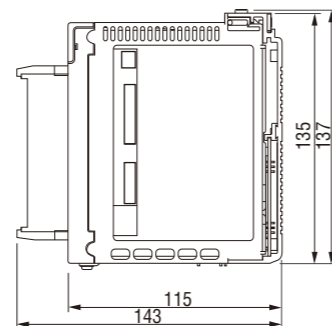

■ TC-net I/O base (Unit:mm)

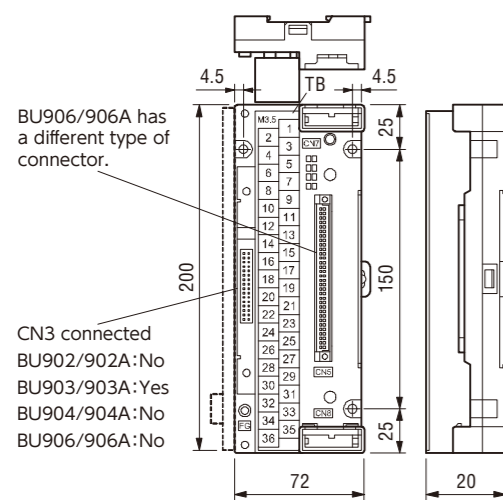

(Note 1) BU902A/903A/904A/906A can have a common bar/short bar attached, but be sure to allow sufficient space for the wiring terminal which may protrude up to 20mm on the left side.