

TC-net I/O Module

Product Name	Product Code	General Name	Description	I/O points	Channel Isolation	SA91* Connect	SA96* Connect
AI918F	HAI918F*S	TC-net I/O Module	Analog Input, 0-5V, 16bit	8	Yes	Yes	No
AI929D	HAI929D*S		Analog Input, 0-20mA, 14bit, with Distributors	16	No	Yes	Yes
AI969	HAI969**S		Analog Input, 10mV, ±20mV, ±50mV, ±100mV, ±1V, ±5V, 16bit	16	Yes	Yes	Yes
AI9A9B	HAI9A9B*S		Analog Input, 1-5V, 16bit	16	No	No	Yes
AI9H9B	HAI9H9B*S		Analog Input, 1-5V, 16bit, with HART communication	16	No	No	Yes
AI9H9C	HAI9H9C*S		Analog Input, 1-5V, 16bit, with HART communication	16	No	No	Yes
TC919	HTC919**S		TC Input, B, R, S, J, K, T, E, 16bit	16	Yes	Yes	Yes
RT918	HRT918**S		RTD Input, Pt100, JPt100, 16bit	8	Yes	Yes	Yes
RT918C	HRT918C*S		RTD Input, Pt100, JPt100, 16bit	8	No	Yes	Yes
AO928	HAO928**S		Analog Output, 0-20mA, 14bit	8	Yes	Yes	Yes
AO9A9B	HAO9A9B*S		Analog Output, 4-20mA, 14bit	16	No	No	Yes
AO9H9B	HAO9H9B*S		Analog Output, 4-20mA, 14bit, with HART communication	16	No	No	Yes
DI934	HDI934**S		Digital Input, DC24V, 5.2mA, Both Sink/Source common type	32	No	Yes	Yes
DI934I	HDI934I*S		Digital Input, DC24V, 4mA, Both Sink/Source common type	32	No	Yes	No
DI935	HDI935**S		Digital Input, DC24V, 4mA, Sink/Source common type	64	No	Yes	Yes
DO934	HDO934**S		Digital Output, DC24V, 100mA, Sink type	32	No	Yes	Yes
DO935	HDO935**S		Digital Output, DC24V, 50mA, Sink type	64	No	Yes	Yes
PI948	HPI948**S		Pulse Input, Contact input 50Hz, Voltage Input 2-30Vp-p/10kHz	8	No	Yes	Yes
PO919	HPO919**S		Pulse Output, DC24V/100mA, Open/Close, Pulse Width/Train, Fast/Slow	16	No	No	Yes
MD911	HMD911**S		Modbus Master/Slave, RS485 2W/4W, RS232C	—	—	Yes	No
FL911	HFL911**S	FL-net, 100BASE-TX/10BASE-T	—	—	Yes	No	

Standard Software Package

Product Code	General Name	Description
ECSMTDDG_02	OIS-DS/Smart Package	English, Windows7, 32/64bit, for application development, USB key
ECSMTRDG_02	OIS-DS/Smart Package	English, Windows7, 32/64bit, for runtime, USB key
HET81E4SS	nV-Tool Engineering Tool	English, Windows7, 32/64bit, for stand alone

Precautions

- Toshiba will bear no responsibility whatsoever for any damages arising from the use of or inability to use this product (including, but not limited to, loss of business profit, interruption of business, loss of business information, or other monetary losses).
- This product is not manufactured for the purpose of being applied to such systems as mentioned below which are directly related to human lives. In the event of the possibility of the product being used for such applications, please contact your Toshiba sales representative.
 - [Example]
 - Main unit control system of a nuclear power plant, safety protection system of a nuclear facility, or any other systems important for safety
 - Operation control system of mass transportation system or air traffic control system
 - Medical control system that has a bearing on human lives
- Use the product correctly after reading the instruction manual.
- This product cannot be used for application products whose manufacture and sale are prohibited by domestic and overseas laws and regulations.
- Export of this product or supply to overseas is restricted by the Foreign Exchange and Foreign Trade Law.
- This product is subject to the export control regulations of the US authorities, and permission from the US government may be necessary for export, depending on the export destination.
- The technical information contained herein is for the purpose of explaining the main operations and applications of the product.
- No guarantee or license is granted in regard to the intellectual property rights or any other rights of Toshiba or third parties arising from its use.

TOSHIBA

TOSHIBA CORPORATION

Social Infrastructure Systems Company

Industrial Systems & Components Division

Instrumentation & Control Equipment Department

72-34 Horikawa-cho, Saiwai-ku, Kawasaki-shi, Kanagawa, 212-8585 Japan

Tel : +81-44-331-1695

- The specifications and designs contained in this catalog are subject to change without notice for design change or other reasons.
- The information contained herein is valid as of November 2015. • Photographs are simulated images.

TOSHIBA
Leading Innovation >>>

Unified Controller nv series™

Small-to-middle Scale DCS

type2 light



High Cost Performance DCS: *type2 light* Meets Requirements for Compact C&I System

For thirty five years or more, DCS products of Toshiba have been applied to process automation systems of power generation, water & wastewater, oil & gas, iron making, mining, chemical, paper & paper mill and cement. In general, the system requirements for conventional DCS are high reliability, high availability, advanced control performance and high capacity. While a large scale DCS is able to manage a few thousands loops per controller, it is expensive to introduce into a plant because of the complex redundant architecture used to reduce the risk of centralized control and operation.

Nowadays global process automation market is looking for DCS products which are easier to introduce with improved cost performance in addition to the conventional DCS requirements. One practical solutions is to introduce properly scaled DCS into each functional plant unit as needed. This reduces the risk of centralized control and operation with reasonable cost. To meet these real needs Toshiba launches a small-to-middle scale DCS into the process automation market in 2015. The DCS, named *type2 light*, manages up to 1,000 tag objects including up to 128 control loops, while maintaining inherited functions from Toshiba's large scale DCS.

High Cost Performance DCS: *type2 light*

Reduces the numbers of processors and power consumption by half, compared to Toshiba's previous DCS, the V-series L2. Furthermore supports existing Intelligent Serial I/O and user application programs, so that cost effective migration to *type2 light* can be done.

Multivendor & High Speed Remote I/O: *TC-net I/O*

Consists of 100Mbps loop network without centralized hub, direct I/O and multivendor network I/O. Modbus, FL-net, Profibus-DP and HART devices can be connected.

C&I Engineer-Oriented Programming: *nV-Tool*

Supports not only IEC61131-3 standard but also user programming & online monitoring by using custom symbols of field sensors & devices, instrument balloons.

Integrated HMI for Small-to-Middle Scale: *OIS-DS/Smart*

Holds the functions of OIS-DS and supports new DCS, *type2 light*, to supervise monitor & operation of up to 4096 tag objects in a small-to-middle scale system, using up to 8 displays.

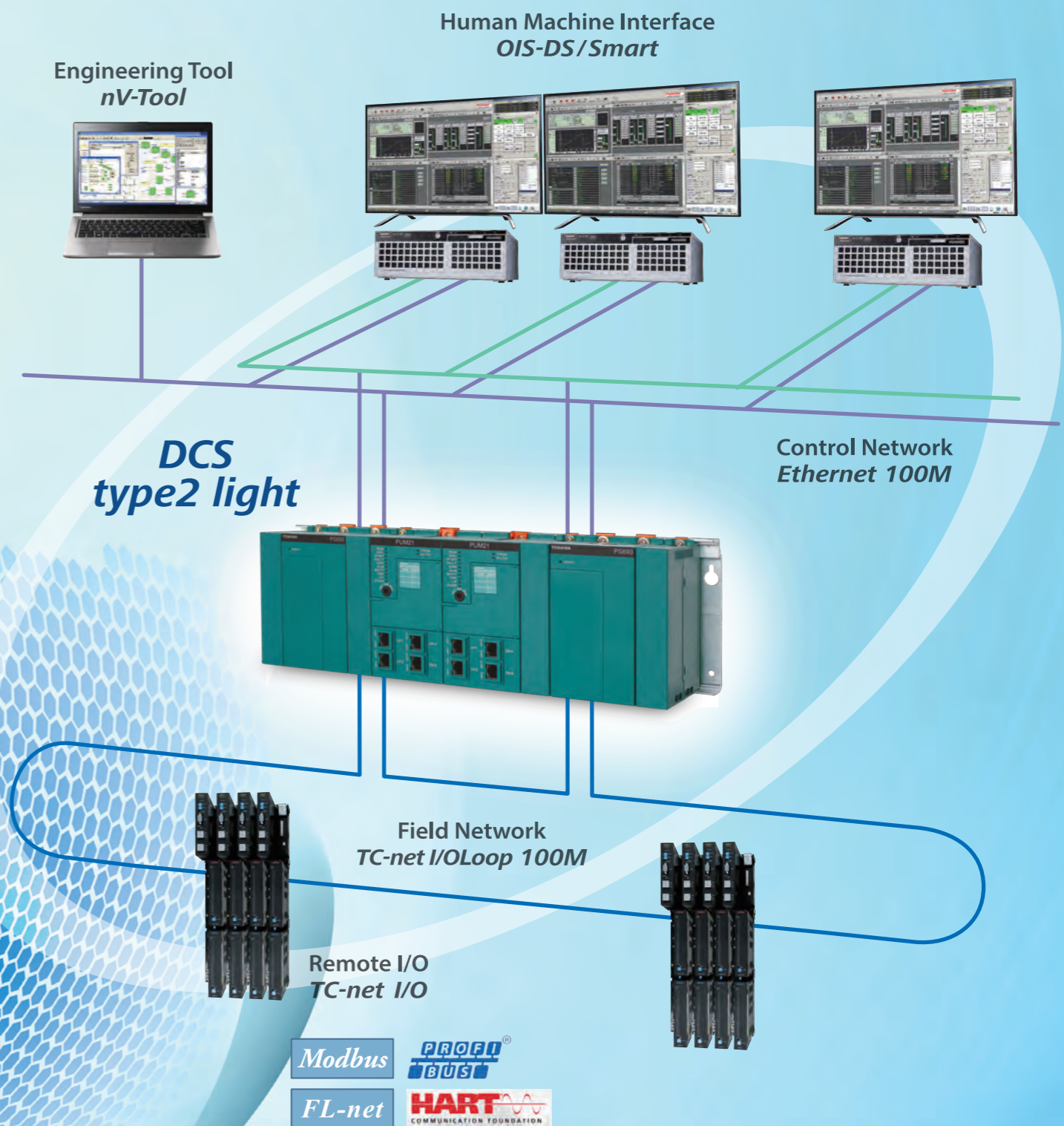

- Unified Controller nv series is a registered trademark of Toshiba Corporation.
- TC-net is a registered trademark of Toshiba Corporation.
- Ethernet is a registered trademark of Xerox Corporation.
- PROFIBUS is a registered trademark of PROFIBUS User Organization.
- Modbus is a registered trademark of Schneider Automation Inc.
- HART is a registered trademark of FieldComm Group.
- Windows is a registered trademark of Microsoft Corporation.

High Cost Performance DCS *type2 light*

High Cost Performance:

Previous DCS of Toshiba, V-series L2, needs two sets of four modules at least in the main unit to realize redundancy. The new DCS, type2 light needs only two sets of two modules to realize redundancy with lower power consumption achieved by using highly integrated technology.

Inheritance from Toshiba DCS:

Succeeding to Toshiba DCS features of Industrial Dual Ethernet, Intelligent Serial I/O, IEC61131-3 Programming, Standard Process Tags and Real Time Database of ONS Sever, type2 light fits into the existing TOSDIC-CIE/DS system, migrating from legacy DCS and utilizing existing user programs.

Sufficient Tag Object Capacity for Small-to-Middle Scale Plant Unit:

Up to 1000 process tag objects consisting of 384 indicators, 128 controllers and 512 discrete devices are available, so that type 2 light is suitable for most of small-to-middle scale plant units.

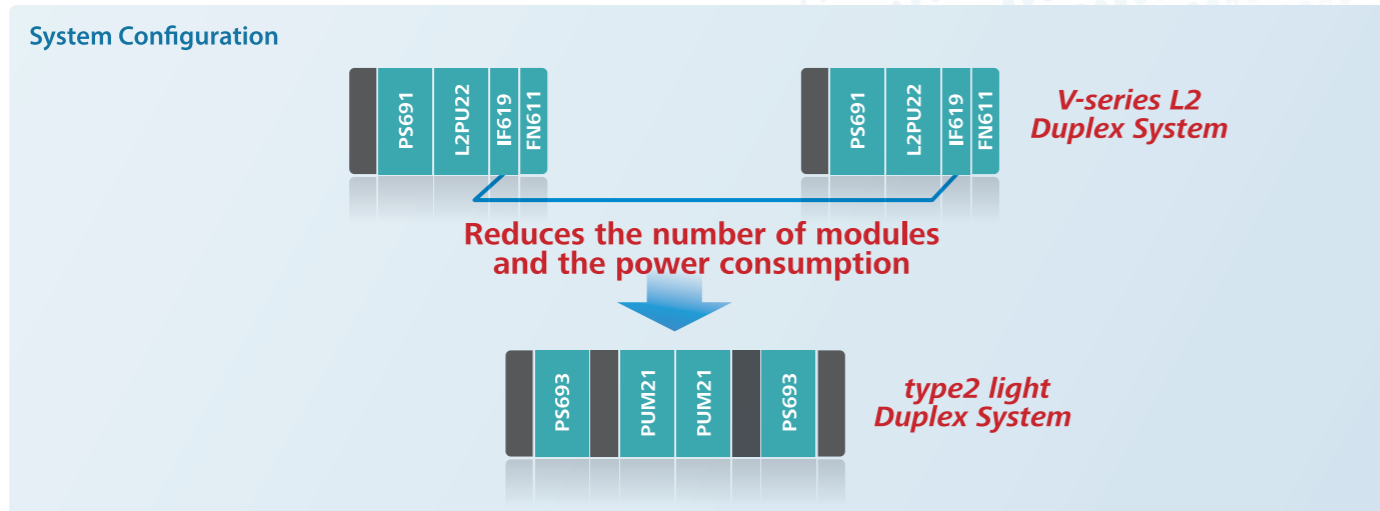

System Specification of type2 light

Category	Item	Description
Main Unit	Redundancy	Single or duplex
	Cooling	Natural air cooling without Fan
CPU	Bit Length, Clock, The Number	32bit, 50Mhz, Two CPUs for main and Ethernet
Memory	Capacity	14.5MB
Ethernet	Interface	RJ45 2 Ports, 100BASE-TX
	Supported Functions	OIS-DS connection (ONS-Server), Communication between controllers, nV-Tool connection
Maintenance	Interface	USB 1 port
	Supported Functions	Firmware download
I/O	Supported I/O subsystem	TC-net I/O, Intelligent Serial I/O
	TC-net I/O Interface	RJ45 2 ports, 100BASE-TX, TC-net I/O Loop (Electrical/Optical) RP913 is needed to connect electrical TC-net I/O Loop and optical one.
	The number of TC-net I/O Modules	256 modules
	Intelligent Serial I/O Interface	SMB21 Module, D-Sub 9 pin 2 ports, Two Intelligent Serial I/O Buses Connectable
	The number of intelligent Serial I/O Modules	420 modules
	Batch I/O data capacity	IQ registers, 16KW
User Program	Batch I/O data updated time	70µs/W or faster, 72ms/KW, 1.1 second/16KW.
	Program language	IEC61131-3, LD, FBD, SFC, ST
	The number of Programs	IEC61131-3, Program, Function Block, Function, totally 1000.
	Program code capacity	128 K steps
	Program variable capacity	Global variables plus Local variables, Total 64KW
Tag Object	Program executing task	Event (EV) 8, Interrupt (IP) 8, High speed scan (HS) 8, Main scan (MS) 64
	Program executing time	HS:10-500ms(1ms unit), MS:100-1000ms(10ms unit)
	Supported Objects	Indicator(#PV), Controller(#LP), PB & Lamp(#PB), Timer/Counter(#TC), Sequence Unit(#SQ), Data Setting(#DB), PLN Table(#P), Timer(#T), Counter(#C), Integer(#W), Real(#R), Real time trend(#RTT)
	The number of Tag Objects	#PV 384, #LP 128, #PB 512, #TC 64, #SQ 64, #DB 128, #P 128, #T 256, #C 128, #W 640, #R 2048, #RTT 512

Multivendor & High Speed Remote I/O *TC-net I/O*

High Speed Definite Response, Optical Networking and Online Maintenance:

type2 light communicates with TC-net I/O Adapters via TC-net I/O Loop based on 100 Mbps Ethernet. TC-net I/O Adapter communicates with TC-net I/O Modules via 10 Mbps TC-net I/O Bus. This system, utilizing TC-net for each layer, enables high speed defined response and remote I/O. TC-net I/O Loop uses a ring topology and does not need any Ethernet switching hub which can be a bottleneck to system reliability due to the hub being a centralized active module connecting several stations. In addition, this loop network is able to continue communication to every station even if a cable connection is broken. For this reason, it is possible to add remote I/O stations or I/O modules online. And furthermore, the TC-net I/O loop is configurable by using not only electrical cables but also optical ones, so that electrical-isolated remote I/O system can be realized.

Multivendor Networking:

I/O system of previous DCS, V-series L2, is Intelligent Serial I/O, which supports direct I/O modules to perform analog/digital input/output. TC-net I/O provides multi roles of input/output from/to 3rd party devices via Modbus, FL-net, Profibus-DP, HART as well as native direct I/O, so that a multivendor networking DCS can be built.

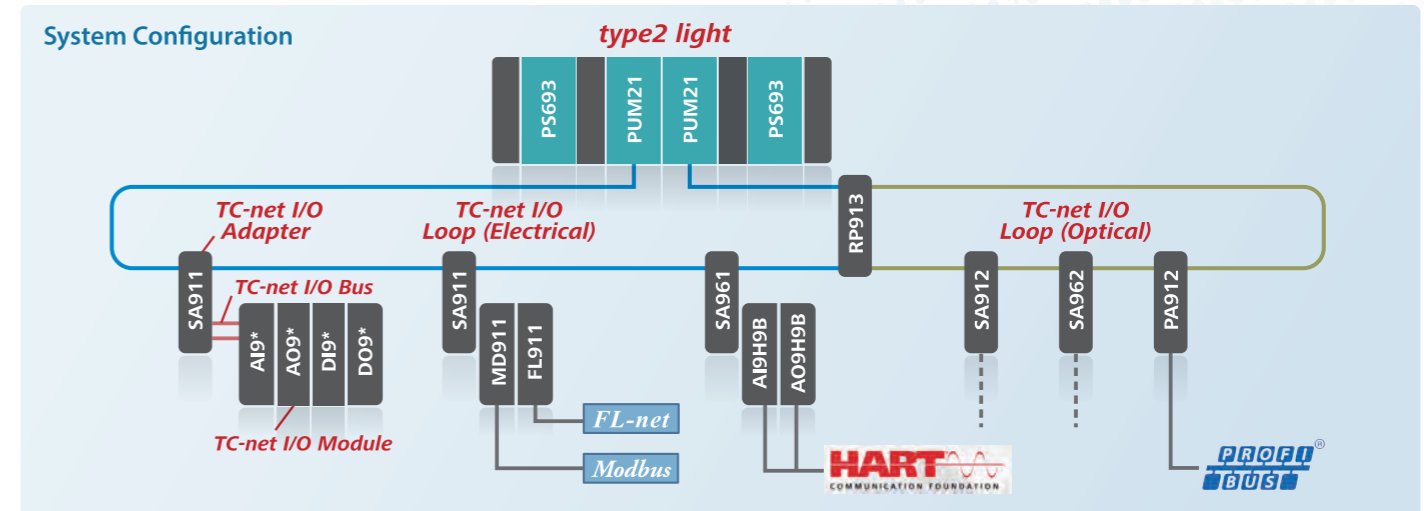

System Specification of TC-net I/O

Category	Item	Description
TC-net I/O Loop	Network Topology	Ring type
	Network Media	Electrical: Cat.5 UTP, Optical: Multi mode 50/125, 62.5/125
	Network Redundancy	Single loop, Continuous communication even if a network connection is broken
	Network Length	Electrical: 10m between stations, total 100m, Optical: 2km between stations, total 4km
	Communication Protocol	TC-net
	Communication Speed	100Mbps
	Online Maintenance	Cable exchangeable
TC-net I/O Adapter	The number of Adapters	16 per TC-net I/O Loop
	Redundancy	Single
	Online Maintenance	Can be added on TC-net I/O Loop
TC-net I/O Bus	Network Topology	Bus type
	Network Media	RS485 2 wire
	Network Redundancy	Dual
	Network Length	5m, both ends shall be connected by terminators
	Communication Protocol	TC-net
TC-net I/O Module	Communication Speed	10Mbps
	The number of Modules	16 per TC-net I/O Bus, 256 per type2 light, except total 16 MD911 plus FL911 per type2 light
	Redundancy	Single
	Online Maintenance	Can be added on in advance installed Base Units
	Modbus Connection	RS485 2W/4W, RS232C, 9600bps/19200bps, Master/Slave, Up to 64 stations.
	FL-net Connection	100BASE-TX/10BASE-T, Up to 254 stations, JDP/IP FA link protocol, Cyclic data transfer
	Profibus-DP Connection	RS485, 9.6K-12Mbps, IEC61158, Profibus-DP Master, DP-V0, Up to 32 stations.
HART Connection	(Supported in future)	

C & I Engineer-Oriented Programming nV-Tool

C&I Engineer-Oriented:

In C&I engineering, the instrument loop diagram has been the foundation of system requirements for control application. Nowadays IEC61131-3 programming is supported by most of DCS as well as PLC. There are big differences between instrument loop diagram and IEC61131-3 one, so that most of C&I engineers and programmers have been struggling with the double maintenance this creates. To reduce the problem, nV-Tool supports Custom Symbols which are attachable to any Function Block of IEC61131-3. By preparing Custom Symbols of field devices and instrument balloons and attaching to functions blocks, you can draw, download and monitor instrument loop diagrams by using these symbols.

IEC61131-3 Standard:

IEC61131-3 is an international standard of control programming language and structure. type2 light supports four well-known languages, as follows.

- LD : Ladder Diagram
- FBD : Function Block Diagram
- SFC : Sequential Function Chart
- ST : Structured Text

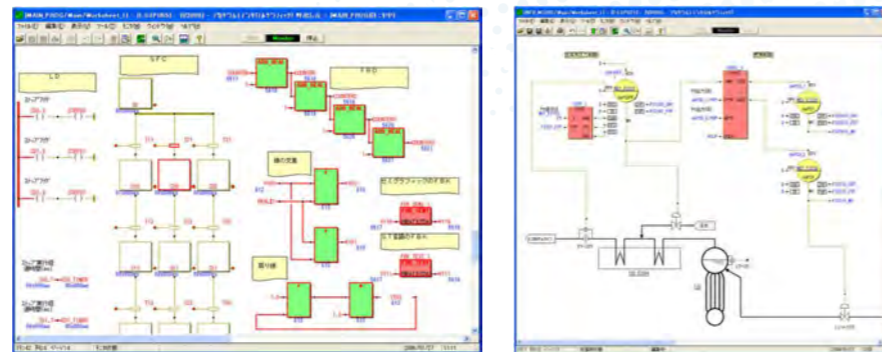

Integrated HMI for Small-to-Middle Scale OIS-DS/Smart

Toshiba has been supplying DCS products of DPCS/MCS in eighties, PCS/PCS-DS/V-series L2/L3 in nineties, nv-series type2 in 2007. And furthermore, a new DCS for small-to-middle scale plant unit, type2 light, has been launched into the process automation market in 2015. OIS-DS is an Integrated HMI subsystem which supervises all the Toshiba DCS shown above.

In addition the functions of OIS-DS have been enhanced to supervise not only Toshiba DCS but also 3rd party PLC, by adding redundant PLCs (PLC Server) into the system in 2010s. OIS-DS is a large scale HMI which manages up to 20,000 tag objects, using up to 22 displays. Inheriting the functions of OIS-DS, OIS-DS/Smart is a high cost performance HMI package for small-to-middle scale system which supervises up to 4096 process tags, using up to 8 displays.



type2 light

Product Name	Product Code	General Name	Description
BUM22	HBUM22**S	Base unit	For type2 light single or duplex. Accepts up to two modules of each P5693, PUM21, SBM21
P5693	GPS693**S	Power module	AC100-240V input, 35W or less, external supply DC24V/0.8A
PUM21	HPUM21**S	CPU module	type2 light main CPU
SBM21	H5BM21**S	SBIF Interface Module	For connecting type2 light and SBIF manage Intelligent Serial I/O. Up to two Bus
BPM21	HBPM21**S	Blank module	For covering an empty slot of left end, right end and SBIF Interface module on a BUM22
BPM22	HBPM22**S		For covering an empty slot of CPU module on a BUM22
BPM2P	HBPM2P**S		For covering an empty slot of Power module on a BUM22

TC-net I/O Loop

Product Name	Product Code	General Name	Description
CM901E	HCM901E	TC-net I/O loop cable (electrical)	1m, Cat.5 UTP cable with RJ45 connectors, One side shield
CM903E	HCM903E		3m, Cat.5 UTP cable with RJ45 connectors, One side shield
CM905E	HCM905E		5m, Cat.5 UTP cable with RJ45 connectors, One side shield
CM907E	HCM907E		7m, Cat.5 UTP cable with RJ45 connectors, One side shield
CM910E	HCM910E		10m, Cat.5 UTP cable with RJ45 connectors, One side shield
RP913	HRP913**S	TC-net I/O Loop Repeater	Electrical/Optical converter
CM901P	HCM901P	TC-net I/O loop cable (optical)	1m, Multimode 50/125, 62.5/125 optical cable with double LC connectors
CM903P	HCM903P		3m, Multimode 50/125, 62.5/125 optical cable with double LC connectors
CM905P	HCM905P		5m, Multimode 50/125, 62.5/125 optical cable with double LC connectors
CM907P	HCM907P		7m, Multimode 50/125, 62.5/125 optical cable with double LC connectors
CM910P	HCM910P		10m, Multimode 50/125, 62.5/125 optical cable with double LC connectors

TC-net I/O Adapter

Product Name	Product Code	General Name	Description
SA911	HSA911**S	TC-net I/O Adapter	Remote station on electrical TC-net I/O Loop, Adapter for TC-net I/O Modules
SA912	HSA912**S		Remote station on optical TC-net I/O Loop, Adapter for TC-net I/O Modules
SA961	HSA961**S		Remote station on electrical TC-net I/O Loop, Adapter for TC-net I/O Modules
SA962	HSA962**S		Remote station on optical TC-net I/O Loop, Adapter for TC-net I/O Modules
PA912	HPA912**S		Remote station on optical TC-net I/O Loop, Profibus-DP Master, with base unit BU90A

TC-net I/O Base Unit

Product Name	Product Code	General Name	Description
BU901	HBU901**S	TC-net I/O Base Unit	For TC-net I/O Adapter
BU902A	HBU902A*S		For TC-net I/O general module
BU903A	HBU903A*S		For TC-net I/O analog input module
BU904A	HBU904A*S		For TC-net I/O TC input module
BU905	HBU905**S		For TC-net I/O 64 points digital input/output module
TR901	HTR901**S	TC-net I/O Bus Terminator	For the end of TC-net I/O Base Unit, included in BU901 as standard
TR928	HTR928**S	TC-net I/O I/V Converter	8 points of 250ohm register with switch for BU903A
TR929	HTR929**S		16 points of 250ohm register with switch for BU903A
CN9C3	HCN9C3	TC-net I/O Bus Cable	3cm, for TC-net I/O Base Unit
CN9C9	HCN9C9		9cm, for TC-net I/O Base Unit
CN9R5	HCN9R5		0.5m, for TC-net I/O Base Unit
CN910S	HCN910S		1m, for TC-net I/O Base Unit
CN920S	HCN920S		2m, for TC-net I/O Base Unit
CN940S	HCN940S		4m, for TC-net I/O Base Unit