

Introduction

The LQ500 density (consistency) meter uses microwave phase shift technology to determine concentrations of solids in the material to be measured flowing through pipes. It can perform a stable and realtime density (consistency) measurement because this technology is not affected by flow velocity along with fluid color, and also is not easily affected by contaminants and low process pressure rate. As the LQ500 has no moving parts, it is reliable and virtually maintenance free.

Since the output of the LQ500 is theoretically linear, it can be applied to a wide range of density (consistency) measurement.

<Notice>

The LQ500 requires a full pipe to measure the density (consistency). If certain amount of bubbles are obviously mixed in measuring media, there are possibilities of causing measuring error. Contact Toshiba before installation in the following cases:

<Possibility of unfilled condition>

- (a) When it is installed at the discharge of a pump.
- (b) When installation is horizontal, and unfilled condition occurs inside the pipe.
- (c) A process where the pipe becomes unfilled when the operation is stopped.

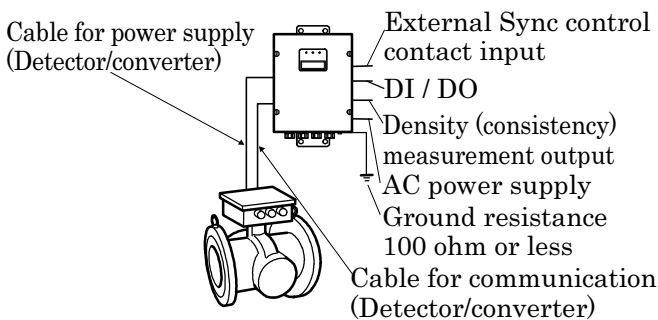

Figure 1. LQ500 Configuration Diagram

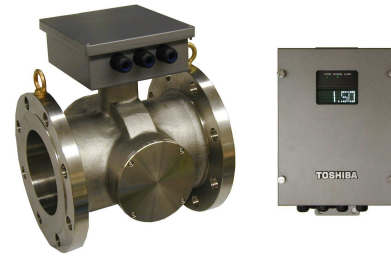

Figure 2. LQ500 Density (consistency) Meter



■ Standard Configuration

- **Density (Consistency) Meter:** 1 set
(Detector and converter separate mounted)
- **Accessories:** 1 set (see Table 1 below)

Table 1. Standard Accessories

Items	Specifications	Quantity
Power supply cable	Between detector and converter (*1)	10 m (32.8 ft)
Communication cable	Between detector and converter (*1)	10 m (32.8 ft)
Fuse	2A(T), 250 V (glass tube, 5.2 dia. x 20 mm)	2
Document	Instruction manual	1

Note 1: Need to prepare a power supply cable for the LQ500. Refer to the section of cable specifications at the overall specifications in detail.

Specifications

■ Overall Specifications

Measurement method:

Microwave phase difference method

Measurement range:

Meter size	50 mm (2")	80 to 300 mm (3" to 12")
Span (*2)	2 to 50 % TS (*1)	1 to 50% TS (*1)
Lower limit setting range (4 mA)	0 to 48% TS	0 to 49% TS
Upper limit setting range (20 mA)	2 to 50% TS	1 to 50% TS
Setting increments	0.1% TS	

*1 TS: Total Solids

*2 Span = Upper range – Lower range

*3 The material to be measured must be fluid and be filled evenly with no voids.

*4 If the density change rapidly (less than 1second), the LQ500 may not measure accurately. The range of measurable density (less than 1 second)

(c = 1.000)

Meter Size	50	80	100	150	200	250	300
Density [% TS]	16.8	10.5	8.4	5.6	4.2	3.4	2.8

Repeatability:

Meter size	50 mm (2'')	80 to 300 mm (3'' to 12'')
Repeatability	±0.02% TS	±0.01% TS

Note 1: Above values are the results of commuting ability in the phase measurements of the converter.

Note 2: Density (consistency) determination repeatability for sample reagent;

Meter size		50 mm (2'')	80 to 300 mm (3'' to 12'')
Density (consistency) determination repeatability	For the full scale value of 2% TS or greater	±2% FS	±2% FS
	For the full scale value of less than 2% TS		±4% FS

*The characteristics of sample reagent has errors due to sample tests such as uneven density (consistency) distribution.

*Full scale is the maximum value in the measurement range, which is the upper limit setting range.

Linearity:

Meter size	50 mm (2'')	80 mm (3'') to 300 mm (12'')
Full-scale 2% TS or more	±2% TS	±2% TS
Less than full-scale 2% TS		±4% TS

Note: The values are taken at measuring points above 5% of full-scale using simulated reagent.

Electric resolution:

Meter size	50 mm (2'')	80 mm (3'') to 300 mm (12'')
Electric resolution	0.002% TS	0.001% TS

Note 1: Above values are the results of commuting ability in the phase measurements of the converter.

Note 2: Density (consistency) determination resolution for sample reagent;

Meter size	50 mm (2'')	80 mm (3'') to 300 mm (12'')
Density(consistency) determination repeatability	0.1% TS	0.05% TS

* The density (consistency) determination resolution stated above is defined due to manufacturing limitation to make reagents with stable distribution and a minimum difference of fluid density (consistency).

<Notice>

1. Install a sample tap near the LQ500 as close as possible to get an accurate density (consistency) measurement using the LQ500.
2. Take several samples in rapid sequence for more accurate density (consistency) measurement with less human error factors.

Environmental conditions:

Items	Temperature range	Humidity range
Detector	Standard: 0 to 50 deg.C (32 to 122 deg.F)	5 to 90% RH (no condensation)
Converter	0 to 50 deg.C (32 to 122 deg.F)	

Structure: Converter: IP65,

Detector: IP67, Watertight

Note: Outdoor installation is possible. However, provide a sunshade for the converter section if direct sunlight is unavoidable.

Microwave power: Approx. 10 mW

Vibration resistance:

No resonance to the following levels of vibration:

- (1) No failure for 5 to 150 Hz with the following acceleration in each device for 30 minutes in each axis of X, Y, and Z (90 minutes); Converter: 4.9 m/s², Detector: 25m/s²
- (2) No failure for 5 to 150Hz with the following acceleration in each device for 3 minutes in each axis of X, Y, and Z, 10 times (90 minutes as total); Converter: 4.9 m/s², Detector: 25m/s²

Note: Avoid using the LQ500 in an environment with constant vibration.

Cables: See the Table 2

Table 2. Cable specifications

Specifications	Cables Between detector (RF part) and converter (*1)		Power supply cable of LQ500 (*2)
	Power supply (24Vdc)	Communication	
Cable type	CVVS-2C-2S	CVVS-5C-1.25S	CVV-3C-2S
Cross-sectional area (*3)	2 mm ²	1.25 mm ²	2 mm ²
Number of cores	2	5	3
Cable diameter (*4)	11 to 13 mm ²	11 to 13 mm ²	11 to 13 mm ²

*1 10m (32.8 ft) length is packed as standard.

*2 Need to prepare this cable by the customer.

*3 Need to use a sheathed cable.

*4 If the diameter of the cable is smaller than the inside diameter of the packing, enlarge the cable diameter to the same size as the packing by wrapping around the cable.

This dimension is coming from a diameter of the cable gland of the LQ500.

Conformance to European Community Directives:

- EMC directive 89/336/EEC
- The low voltage 93/68/EEC

Approved hazardous locations certification:

UL/CUL Class I, Division 2, Groups A, B, C and D (UL/CUL only for explosion proof)

Weight: Refer to Outline Dimensions (Table 3).

Part 15 of the FCC rules: Certified.

■ Detector Specifications

Meter size: 50mm (2"), 80mm (3"), 100mm (4"), 150mm (6"), 200mm (8"), 250mm (10"), and 300mm (12")

Flange standard and maximum working pressure:

Flange standard	Maximum working pressure
ANSI Class 150	1 MPa (150 psi)
DIN10 and BS10	1 MPa (10 bar)
DIN 16	1.6 MPa (16 bar)
JIS 10K	1 MPa (10 kgf/cm ²)

Note: Each product was passed a hydraulic test under twice pressure rate for 15 minutes toward the specification.

Fluid temperature:

0 to 100 deg.C (32 to 212 deg.F) without freezing and bubbles conditions

Allowable fluid conductivity:

Meter size	Fluid conductivity
50 mm (2")	20 mS/cm maximum
80 mm (3")	16 mS/cm maximum
100 mm (4")	15 mS/cm maximum
150 mm (6")	10 mS/cm maximum
200 mm (8")	8 mS/cm maximum
250 mm (10")	8 mS/cm maximum
300 mm (12")	6 mS/cm maximum

Note 1: The LQ500 can not have an accurate density (consistency) measurement when it is over the specification according to reduce the microwave signal.

Note 2: The LQ500 density (consistency) measurement for application where liquids containing highly conductive particles such as active carbon and metal particles may be affected. Consult Toshiba for detail when the measuring liquid contains such particles.

Note 3: Even within the range of conductivity specification, the density (consistency) readings will change if the value of fluid conductivity varies. For example, if fluid conductivity value changes 1mS/cm, it effects to fluctuates density (consistency) readings about 0.15% TS. If conductivity change seems to influence the measurement reading, please utilize conductivity correction function.

Wetting materials:

Name	Materials (*1)
Main pipe	SCS14A cast (equivalent to 316 SS) (standard) (*2, *3)
Temperature detector sheath	316 stainless steel (*4)
Applicator window	Polysulfone (*4)
Applicator window sealant	Fluoric rubber

*1 Avoid using the LQ500 for applications where harmful liquids that cause corrosion, deterioration, or changes in quantity for the wetting materials are used.

Make sure all materials at these wetting parts that are suitable for your CIP or not before cleaning.

*2 The smoothness inside the pipe on this material is;

Type	Meter size	Smoothness
Standard type	50 to 200 mm (2" to 8")	No buffing
	250 & 300 mm (10" & 12")	Buffing # 150
Option type	50 to 300 mm (2" to 12")	Buffing # 150

*3 State the wetted materials when you choose these options.

*4 The materials of them are changed for abrasive applications.

Need to choose the specification code for this application.

Applicator:

Serves as an antenna to send and receive microwave signals, one set provided.

Temperature detector: RTD (Pt100)

Fitting:

Direct fitting to vertical or horizontal piping. (Refer to the section of Piping Precautions.)

■ Converter Specifications

Output signals

- **Density (consistency) measurement output:**

4-20mA_{dc} (load resistance 750 ohm maximum, isolated output.)

- **Density (consistency) fault or Maintenance signal:**

125V_{ac}, 0.1A (resistive load) solid state contact; opens when an error occurs in the converter or when the LQ500 is in the setting change mode, otherwise the contact remains closed.

- **Communication signal:**

Digital signal is superimposed on 4-20mA_{dc} current signal (conforming to HART protocol (*1)).

Load resistance: 240 to 750 ohm

Load capacity: 0.25μF maximum

*1 HART (Highway Addressable Remote Transducer) protocol is a communications protocol for industrial sensors recommended by HCF (HART Communication Foundation).

Note: The optional BF100 configurator can be used to operate the LQ500 from remote places by connecting the communication cable between the LQ500's 4-20 mA dc output signal lines.

Input signals

- **External synchronized input signal:**

In order to avoid problems of density (consistency) measurement such as inhomogeneous condition caused by discontinuous process operation and empty pipe condition caused by stopping process operation.

<Specification>

One dry "make" contact;

Contact capacity of approximately 5V_{dc}. 0.1A is required. This contact signal can be used to start or stop density (consistency) measurement in synchronization with an external contact, such as the contacts on a pump.

The measurement starts or stops as follows:

Contact closed: Starts density (consistency) measurement.

Contact open: Stops density (consistency) measurement.

- **Density multiplier switching signal:**

In order to achieve selecting up to 4 kinds of liquid concentration measurement independently as maximum.

<Specification>

Two voltage signals described below are required:

Input voltage: H level: 20 to 30 V_{dc}

L level: 2 V_{dc} or less

Input resistance: Approx. 3k ohm

- **Internal conductivity correction function:**

This function reduces the influence (density variation) of the conductivity changing by using the measured value of LQ500. Thus, this function does not need to input the conductivity meter signal (the correction factor of this function is calibrated with sodium chloride). If this function (Internal conductivity correction) does not reduce the density variation by the conductivity changing, you can use "External Conductivity correction".

- **External conductivity correction function:**

Conductivity correction signal:

Needs to prepare an additional conductivity meter when using this function. Install in where is able to have a stable and accurate measurement.

<Specification>

Input signal: 4 to 20mA_{dc}

Conductivity range: 0 to 10mS/cm

Update period for density (consistency)

measurement output and display: Approx. 1 second

Functions by software as standard:

- **Data saving function:**

In order to save measurement data into the memory of converter temporary.
The oldest data is overwritten.

<Specification>

Data storage points: 256 points maximum.

Period: 1 to 1,800 minutes (1 minute each).

ex 1: The data is saved for approx. latest 4.26 hours when programming every minute.

ex 2: The data is saved for approx. latest 21.3 hours when programming every 5 minutes.

- **Moving average function:**

In order to keep the average density (consistency) output, or in order to suppress the deflection width of the output. It helps for density (consistency) control.

<Specification>

Enable to determine a number from 1 to 999.

- **Change-rate limit function:**

In order to reject the transient density (consistency) output as noises, or a sudden variation in the output according to intrusion by bubbles, etc....

<Specification>

Allowable rate of change limit: 0.00 to 9.99% TS

Enable to determine a number from 0 to 99.

- **Additive correction function:**

Capable of handling up to ten brands, this function performs the sensitivity correction appropriate to the additives type and compound ratio in accordance with the parameters that are registered in advance.

- **Password function:**

This function is used to limit access to changing parameters that affect measured data by means of a password.

- **Number of Rotation N fixed function:**

This function is used to fix the number of angle rotation N when the external synchronized operation starts.

(LQ500 measure the phase of microwave, and calculate the density from the phase changes. Because the phase is limited from 0 degree to 360 degree, LQ500 use the rotation N when the phase is over 360degree. But the range of density is wide over the 360 degree, LQ500 may not know the number of the rotation N when the pump starts. If the density is constant when the pump starts,

LQ500 can set the number of rotation N, and measure the correct density(consistency)).

Arrestor:

Arrestors are installed in the LQ500 current output (4-20mAdc) and AC power lines.

Operation panel and Display:

Used to check data or change various settings.

Operation switches: 5 switches.

Display: 4-line, 20-character VFD(dot-matrix)

Power supply:

100 to 240Vac 50/60Hz (Allowable voltage: 85 to 264Vac)

Note1: An additional power supply is required when choosing an optional environmental temperature specification type (-20 to 50 deg.C).

Refer to the section of Environmental conditions in detail.

Note2: UL/CUL Hazardous locations type does not have a power switch. Please prepare a power switch outside. (Rated 250V AC,10A above, DPST: Double-Pole/Single-Throw) Use the power switch for Hazardous locations in Hazardous locations area.

Power consumption:

Approx. 25VA (100Vac), Approx. 35VA (240Vac)

Housing material: Steel plate**Coating:** Polyurethane

MTBF: 135.8 months under 25 deg. C (77 deg. F) based on MLL-HDBK-217F

Installation

■ Outline Dimensions

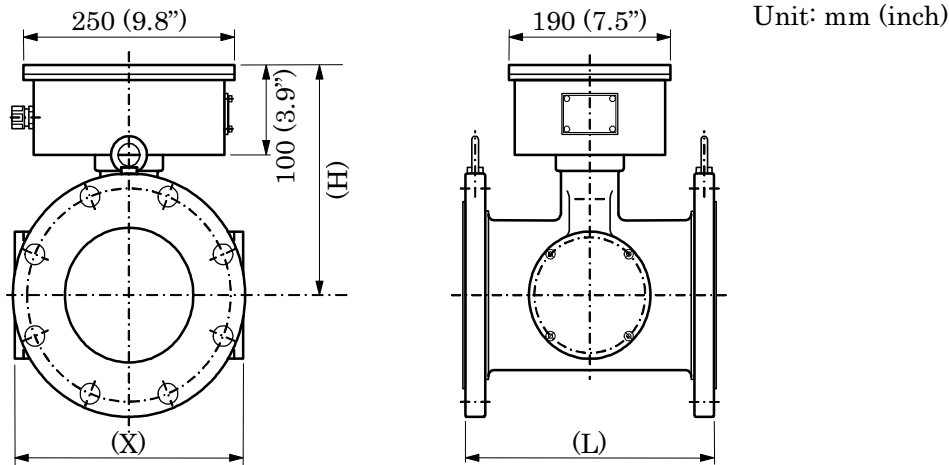

Figure 3. LQ500 detector outline dimensions

Table 3. LQ500 detector outline dimensions

Size mm (inch)	Dimensions, Unit: mm (inch)			Weight, Unit: kg (lbs)			
	X	H	L	DIN 10	DIN 16	ANSI 150	JIS 10K
50 (2")	170 (6.7")	225 (8.9")	300 (11.8")	Approx. 22	Approx. 22	Approx. 21 (46 lb)	Approx. 21
80 (3")	200 (7.9")	225 (8.9")	300 (11.8")	Approx. 30	Approx. 30	Approx. 31 (68 lb)	Approx. 26
100 (4")	220 (8.7")	240 (9.4")	300 (11.8")	Approx. 31	Approx. 31	Approx. 34 (75 lb)	Approx. 29
150 (6")	270 (10.6")	260 (10.2")	300 (11.8")	Approx. 43	Approx. 43	Approx. 44 (97 lb)	Approx. 42
200 (8")	320 (12.6")	290 (11.4")	300 (11.8")	Approx. 50	Approx. 52	Approx. 54 (119 lb)	Approx. 48
250 (10")	300 (11.8")	315 (12.4")	350 (13.8")	Approx. 65	Approx. 68	Approx. 68 (150 lb)	Approx. 64
300 (12")	360 (14.2")	340 (13.4")	350 (13.8")	Approx. 78	Approx. 85	Approx. 99 (218 lb)	Approx. 76

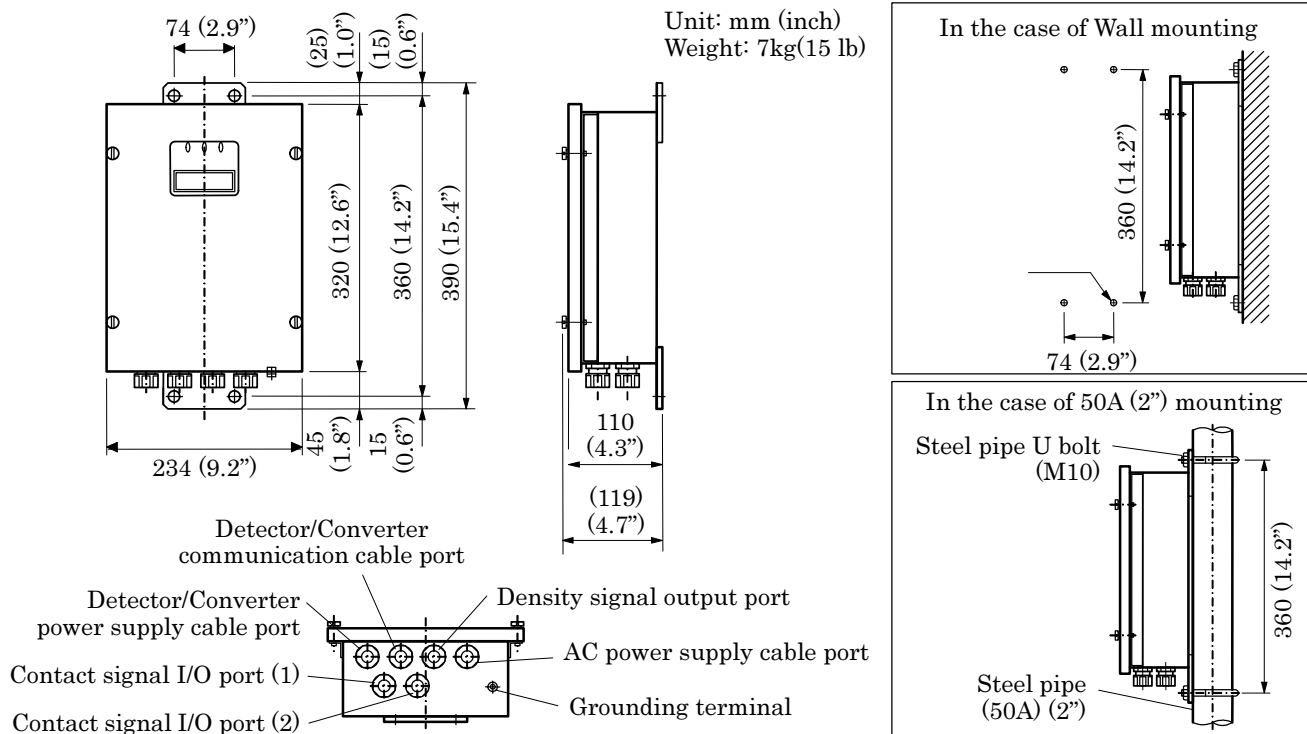

Figure 4. LQ500 Converter outline dimensions

■ Installation Precautions

- (1) Choose a place that is free of vibrations and corrosive gasses, and has ample space for maintenance.
- (2) Secure maintenance space around the converter and detector RF section. (Refer to Figure 5)
- (3) In the case of outdoor installation, provide covering against sun and rain.
- (4) It is recommended that the converter be installed about 1.5m (the position of windows) from the floor. The VFD display stays on the front panel of the density meter. Install the converter in a location and orientation easy to see this VFD display.
- (5) Do not install the meter in a place where there is a possibility of leakage of flammable or explosive gas.
- (6) Do not install the meter in any of the following places:
 - A place where condensation due to a sudden temperature change occurs.
 - A place where extreme low or high temperatures occur outside the specification range.
 - A place near the equipment generating strong radio waves or electric fields.
- (7) Install the meter in a place where air bubbles are not generated, inside the pipe is always filled, and sedimentation and accumulation of solid matters do not occur.
- (8) Install the meter in a place where density distribution is uniform. If the distribution inside the pipe is uneven, manual analysis data and the indicated value of the density meter may not show the same value.
- (9) Ensure that the flow rate of the fluid to be measured is 0.6m/s or more.
- (10) Make sure the upstream and downstream pipes have enough strength to hold the density meter. If it is not possible, provide a supporting base to hold the density meter.
- (11) The liquid contacting materials of this meter are Detector pipe: SUS316L, Measuring window: Polyetheretherketone, O-ring: Silicon rubber, Liquid temperature sensor: SUS316L. Install the meter in a place where measuring liquid or environment does not corrode these materials.
- (12) When multiple density meters are installed, a combination of each converter and its detector should be kept correctly. If the converter is installed with a different detector, density measurement may not be performed correctly.
- (13) If the density change rapidly (less than 1 second), the LQ500 may not measure accurately. The range of measurable density (less than 1 second)

(c = 1.000)

Meter Size	50	80	100	150	200	250	300
Density [% TS]	16.8	10.5	8.4	5.6	4.2	3.4	2.8

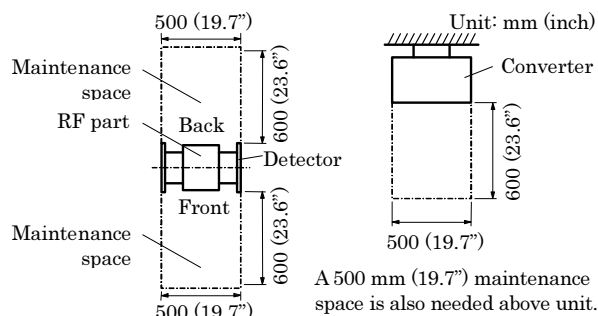

Figure 5. Clearance space

■ Piping Precautions

- (1) Install the meter in a place where density distribution is uniform. If the density distribution in the density meter pipe is uneven, manually obtained analysis value and the density meter indicated value may be different..
- (2) Install the density meter in a location where the material to be measured flows and fills inside the detector pipe and bubbles do not remain. If the material to be measured does not fill the pipe or bubbles remain, a measurement error occurs or the density indication fluctuates. If there is a possibility of such a condition, we recommend you to avoid installing the density meter on the suction side of a pump and instead install it on the pump discharge side.
- (3) Avoid such a location where the measured matter will settle and build up on the bottom of the density meter.
- (4) Avoid such a location which will allow bubbles to move into the pipe line.
- (5) We recommend that this density meter should be installed to a vertical piping system. Horizontal installation can also be used with the same performance but under the following conditions, vertical installation must be recommended:
 - a) Bubbles may stay in the pipe.
 - b) Slow flow speed or other factors may cause the measured matter to sink or float substantially making the distribution of the measured-matter density uneven in the pipe.
 - c) The main pipe has been enlarged thus using the density meter of a diameter greater than that of the main pipe.
- (6) When installing on the horizontal piping, make sure that RF section must be on the top for purposes of maintenance and performance assurance (in other words, so that the paired applicator sections are placed directly side by side).
- (7) This density meter does not distinguish between the upstream side and the downstream side. Neither does it require a straight tube length. Install it in a direction that will make maintenance easy.
- (8) When you anticipate a marginal error between the side-to-side dimensions of this density meter and the installation space of the piping line,

prepare a loose mechanism in advance.

- (9) To minimize the impact of the bubbles mingled, it is recommended that the meter be installed on a location as far as possible from the pipe outlet for air release but still within the distance where a reasonable degree of hydraulic pressure is applied.
- (10) In the event that the density meter may no longer be full of the fluid while the pump is shut down or the density distribution in the density meter may become uneven, make sure to take measurements only while the pump is operating by using the external synclonized function.
- (11) Take necessary measures to prevent vibration from a pump or other equipment applied to the density meter transmitted through the piping.
- (12) On both the upstream and downstream sides of the density meter, install stop valves. Furthermore, between these valves and the density meter, install the sampling port, the zero water supply port, the air release port, the drain port with a stop valve attached respectively. In the event that the flow of the pipe line cannot be stopped, provide a bypass pipe halfway with a stop valve attached. When performing zero point calibration, these are needed to discharge the measured matter out of the density meter through its drain port and fill up the meter with fresh water of zero density. (See Figure 6 and Figure 7)
- (13) As for gaskets to be used in piping, select the one with the dimension conforming to the flange standard and of the material appropriate for the substance to be measured.
- (14) The front side of the density meter's converter section is equipped with an VFD density display section. When installing the meter, choose a location and direction in which this density display section will be easily visible.
- (15) If the cover of the density meter is removed or the density meter is disassembled while the meter is powered, radio waves will leak out. (However, the amount is about equal to PHS and one tenth of mobile phones.)
- (16) For both horizontal and vertical piping systems, install a support stand under the density meter with bolts put through the installation holes (M8 size) on the bottom of the density meter. Then install the support stand together with the density meter to a solid ground or wall. Bolts (four M8 bolts) are not attached as accessories of the density meter. Please prepare these bolts separately

NOTE:

• **Zero point water valve:**

Used to supply drinking water (density or consistency 0%) to the detector pipe for zero point adjustment. Install this valve at the top of the pipe in the case of horizontal installation. It is recommended that a 1-inch ball valve be installed on the top of the pipe and zero point water supplied through this inlet using a vinyl hose etc.

Note: If valve water pipe is connected to this valve, air cannot be extracted. Therefore, another valve (vent valve) is needed to extract air.

• **Vent valve:**

Used to vent process fluids to open air when performing zero adjustment. This helps the drinking water (density or consistency 0%) enter the detector pipe easily. Install this valve on the top of the pipe in the case of horizontal installation.

• **Drain valve:**

Used to drain the fluids before supplying drinking water (density or consistency 0%) to the detector pipe for zero adjustment. Install this valve at the lowest point of the pipe. It is recommended that a 1-inch ball valve be installed at the lowest point of the pipe.

• **Sampling valve:**

Used to extract fluids for manual analysis. Install this valve to the side of the pipe in the case of horizontal installation. It is recommended that a 1-inch ball valve be installed to the side of the pipe.

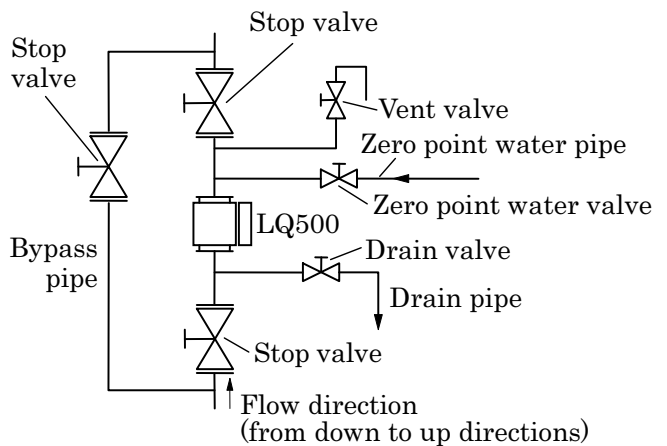

Figure 6. Recommended Installation (vertical installation)

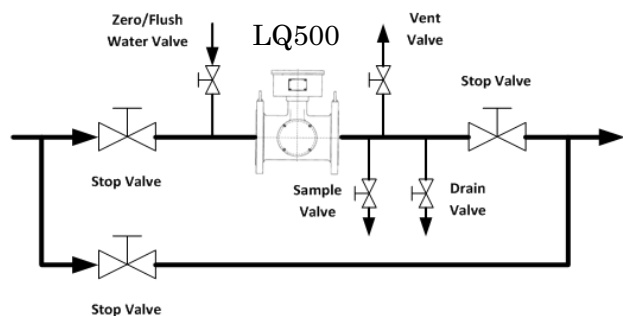
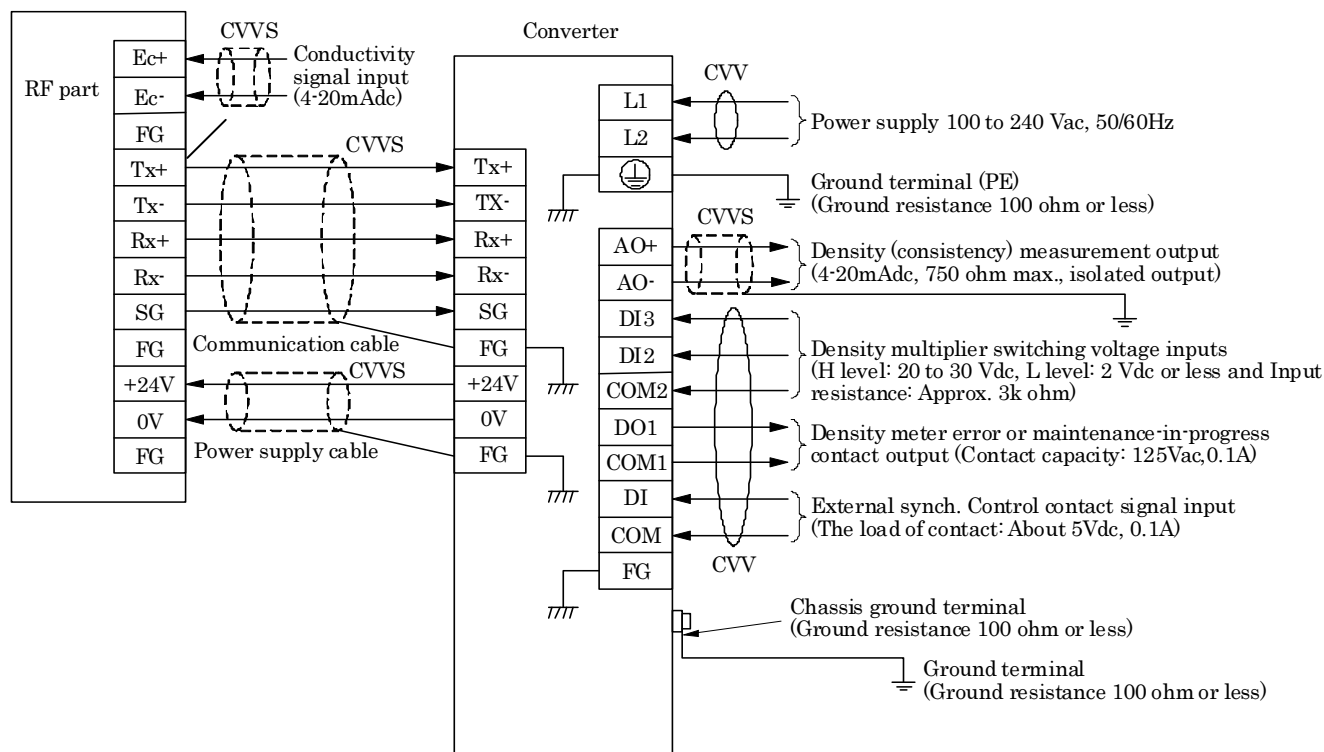

Figure 7. Horizontal installation (*inside the pipe is always filled)

■ Wiring Precautions

- (1) Provide a switch and a fuse to isolate the unit from the mains power for ease of maintenance.
- (2) Ground the LQ500 with 100 ohm or less ground resistance. Do not use a common ground shared by other power equipment.
- (3) Use the accessories cables for communication and power supply between detector and converter. Connect cables to the terminals that match the marking on the cables.
- (4) Use a sheathed cable with 2mm² cross-sectional area for AC power cable.
- (5) The cables should be free from vibration and should have no slack in the cables.
- (6) Wire the LQ500 output in conduit separated from those of AC power cable, control signals, alarm signal or other cables which could become the source of noise.
- (7) Use a 2-wire shielded sheathed cable to wire the LQ500 output (4-20mA_dc) and conductivity signal. Ground the shielded cable on the receiving instrument side for both cable.
- (8) As the cable port is made air-tight using a packing, tighten the cable gland securely when all the wiring is completed. If the diameter of the cable is smaller than the inside diameter of the packing, enlarge the cable diameter to the same size as the packing by wrapping valves around the cable. Its suitable diameter is 11mm. Tighten the terminal screws securely. Its suitable torque is 1.0 to 1.7 N·m.
- (9) Screws at the terminals are needed to tighten with 1.2 N·m torque (1.4 N·m is maximum).
- (10) Do not turn on the power supply under the uninstalled condition.
- (11) Each cable in the communication cable and power supply cable between detector and converter has banded marks for each terminal. Connect them correctly without any mismatches.



Notice 1: Do not connect to the “FG” terminals neither communication cable nor power supply cable in the detector side.

Notice 2: Either “PE” terminal on the terminal block in the converter on the chassis ground terminal of the unit should be grounded with 100 ohm or less ground.

Notice 3: Ground the shielded cable on the receiving instrument side.

Notice 4: UL/CUL Hazardous locations type does not have a power switch. Please prepare a power switch outside. (Rated 250V AC, 10A above, DPST: Double-Pole/Single-Throw)

Figure 8. External connections

About BF 100 configurator

The optional BF100 configurator is a software package that you can operate the LQ500 from remote places. Please prepare the personal computer. Before you use the BF100 software package, you install the BF100 software package to the personal computer following,

OS: Microsoft Window XP Professional/ Home(SP3)

Microsoft Windows Vista

Business/Home(SP2/32bit)

Microsoft Windows 7 Professional/ Home(32bit)

CPU: To meet the requirement of the OS.

RAM: To meet the requirement of the OS.

Display: Equal to or greater than XGA.

Interface: COMM (RS232C: D-sub9pin) or
USB (USB1.1/2.0; A type)

CD-ROM drive is needed.

Language: English

Microsoft®, Windows® is registered trade marks of Microsoft Corporation in the United State and other countries.

The communication method between the BF100 and LQ500 is HART protocol.

To use the BF100 needs the HART communication cable. If you don't have the HART communication cable, please order the HART communication cable (option).

•Wiring when communications function is used

By connecting the cable lead of the optional BF100 configurator to the density (consistency) measurement output, you can operate the LQ500 from remote places.

(1) Make sure the load resistance of 4-20mA dc line of output is between 240 and 750 ohm, and the load capacitance is 0.25 μ F maximum.

(2) The BF100's cable lead can be connected to the LQ500 anywhere along the current output line. For example, the cable lead may be connected to the signal terminals on the receiving side in the control room. See Figure 9.

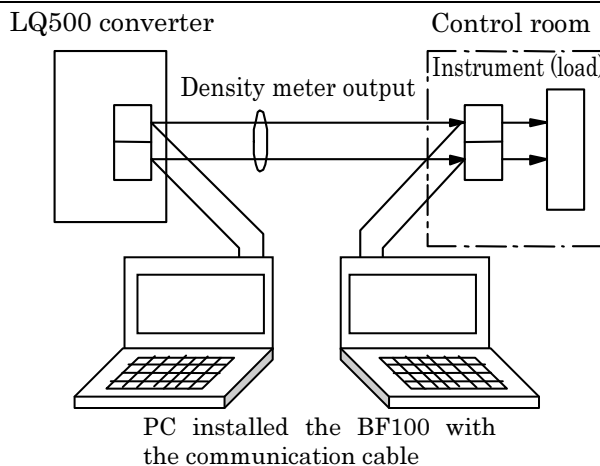

Figure 9. Wiring for communication function

Ordering Information

When ordering the LQ500, refer to Table 4. Type Specification Code. An entry must be made for each of the columns.

The following items must also be specified:

1. Fluid characteristics:
 - Type of material to be measured
 - Density (consistency) (max., normal, min.)
 - Temperature (max., normal, min.)
 - Pressure (max., normal, min.)
 - Conductivity (max., normal)
2. Measurement range
3. Tag number (specify "None" if not needed)
4. The configurator BF100 Required or not (Refer to Table 5 below.)
5. Other specific items

**Table 4. Type Specification Code
(LQ500 Density (consistency) Meter)**

TYPE					CAT Code							SPECIFICATION
1	2	3	4	5	6	7	8	9	10	11	12	
L	Q	5	0	0								Microwave Density (Consistency) Meter
					A							Standard
												Meter Size
						0	5					50mm (2")
						0	8					80mm (3")
						1	0					100mm (4")
						1	5					150mm (6")
						2	0					200mm (8")
						2	5					250mm (10")
						3	0					300mm (12")
												Mounting Style
					B							JIS 10K flange connection
					C							ANSI 150 flange connection
					E							DIN 10 flange connection
					F							DIN 16 flange connection
												Purpose
					A							Standard
					C							for UL/CUL Hazardous locations type
												Wetting parts
					A							SCS14A cast (Equivalent to 316L SS) pipe (standard)
					B							SCS14A cast (Equivalent to 316L SS) pipe with teflon PFA coating for sticky application
					C							SCS14A cast (Equivalent to 316L SS) pipe for abrasive application (Note 2)
												Cable length between detector (RF part) & converter
					A							10 m (32.8 ft) (standard)
					B							20 m (65.6 ft)
					C							30 m (98.4 ft)
					D							40 m (131.2 ft)
					E							50 m (164 ft)
					X							None (Note 2)

Note 1: The differences between standard type are RTD sensor and Applicator window.

Note 2: Toshiba recommends to using our specified cable.

**Table 5. Type Specification Code
(BF100 Hand-held Terminal)**

Model					Specification Code						Description
1	2	3	4	5	6	7	8	9	10	11	
B	F	1	0	0	1	A	A	A	A	1	Standard

Option : communication cable

Communication cable	Order code
COMM type (D-sub9pin)	E000308P2
USB type	E000308P3

ISO9001 and ISO14001 are certified.



Misuse of this product can result in damages to property or human injury.
Read related manuals carefully before using this product.

Specifications are subject to change without notice.
©Toshiba Infrastructure Systems & Solutions Corporation
2017

All Rights Reserved.