

**Introduction**

Capacitance type electromagnetic flow meter sanitary type LF511/LF541(LF516/LF546) is designed for applications handling food and beverages. Sanitary flowmeters must be structured in such a way that operation and handling is simple, easy and thorough for the purpose of sanitary control such as cleaning (CIP/SIP), sterilization and drying. The sanitary flowmeter has features provided with normal electromagnetic flowmeters and by using sanitary fittings for pipeline connections fluid does not remain in any place along the detector pipeline. Therefore, it is fit for flow rate measurement for food and beverages.

The electromagnetic flowmeter uses Faraday’s Law of electromagnetic induction to measure the process flow. The device consists of two units: a detector, through which the fluid to be measured flows and in which low-level signals proportional to flow rates are obtained; and a converter, which supplies excitation current to the detector, and amplifies the signals from the detector and then processes and converts the signals into the 4–20mA<sub>dc</sub> current signal.

The capacitance type Electromagnetic flowmeter, model LF511/LF541(LF516/LF546) employs the surface electrode system outside the alumina ceramic tube, therefore, the electrodes do not come in contact with the process fluid. Its unique technology and mechanical design, make it available for use not only on conventional applications but also on new applications such as low conductivity, abrasive and high concentration slurry.

The LF511(LF516)detector can mount with the LF541 (LF546) converter as combined type.

The alumina ceramic tube for LF511(LF516) detector is highly resistant to extreme temperatures and negative pressure.

The multi-functional LF541(LF546) converter equipped with its patent **Noise-Sentry** original noise-suppression circuit and advanced algorithms. Therefore, this flowmeter is highly resistant to noise and provides a stable output even for fluids containing slurries.

HART\*<sup>1</sup> communicator can be used to communicate with the flowmeter from a remote place. PROFIBUS-PA\*<sup>2</sup> is available as an option.

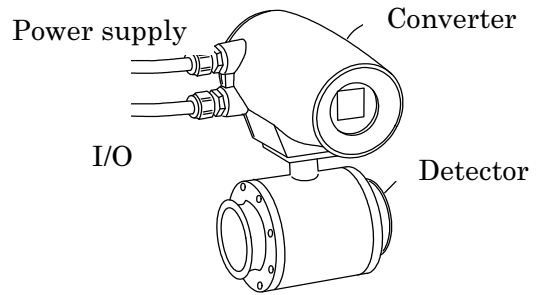

**Combined type  
 LF511/LF541  
 LF516/LF546**

**Figure 1. Configuration**



**Figure 2. LF511/LF541  
 LF516/LF546**



Certification number  
 Z01207

\*1: HART protocol (Highway Addressable Remote Transducer) is a communication protocol for industrial sensors recommended by the HCF (HART Communication Foundation).

\*\* DevComm2000 Smart Device Communicator available for performing HART device configurations on PC or laptop is available through the supplier.

\*2: PROFIBUS is the communications protocol for factory and process automation that the PROFIBUS Organization recommends. Instead of analog control with a conventional analog signal (4-20 mA), it is fieldbus which digitizes all signals. Flowmeters support PROFIBUS-PA.

## Specifications

### Overall Specifications

**Measurement range in terms of flow velocity:**  
1.64ft/s to 32.8ft/s(0.5m/s to 10m/s)

**Accuracy:** See the following table.

Flow rate as a percent of range	Accuracy	
	1.64 – 3.28 ft/s (0.5 – 1.0 m/s)	3.28 – 32.8 ft/s (1.0 – 10 m/s)
0 – 50%	+/- 0.5 %FS	+/- 0.25 %FS
50 – 100%		+/- 0.5 % of rate

**Note:** The accuracy above is measured under standard operating conditions using the weighing method at Toshiba's flow calibration facility.

**Fluid conductivity:** 0.01  $\mu$  S/cm minimum

**Note 1:** Refer to the following relationship between conductivity and fluid velocity.

**Note 2:** Please contact Toshiba before ordering when the fluid conductivity is under 0.1  $\mu$  S/cm.

**Trial test is highly recommended for the application under 0.1  $\mu$  S/cm.**

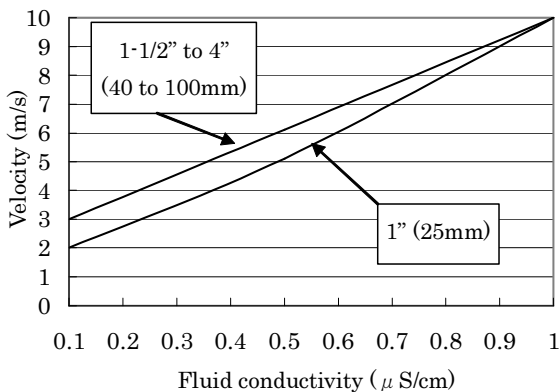

**Fluid temperature:**

14 to 248 °F (-10 to 120 °C)

**Ambient temperature:**

14 to 122 °F (-10 to 50 °C)

**Note:** Contact Toshiba before ordering when the ambient temperature is over 122 °F (50 °C).

**Structure:** IP67 and NEMA 4 Watertight

**Power consumption:** approximately 15W(24VA)

Approved hazardous location certifications:

**Model:LF516/LF546**

cFMus Nonincendive for use in

hazardous (classified) locations:

Class I, II, III, Division 2, Groups A-G

**Detector and converter combination:**

LF511/LF541: Combined type for standard specification.

LF516/LF546: Combined type with Ex Approval of Class I, II, III, Division 2 (cFMus).

**CIP Condition:**

The fluid temperature and pressure of CIP condition must not exceed the specification of the flowmeter. In addition, do not apply this flowmeter to fluids that may corrode, deteriorate or degenerate the product contact surface materials such as Ferrule material, Alumina Ceramic and Silicone rubber.

**SIP Condition:**

The fluid temperature, time and pressure of SIP condition must not exceed the specification as follows.

Temperature : 257 degree F (125 degree C)

Time : 60 minutes

Pressure : 145 psi (1.0MPa)

### Model LF511 and LF516 Detector

**Fluid pressure:**

-15 to 150 psi, or -1.0 to 10 bar (-0.1 to 1.0MPa)

**Note:** The test pressure before shipping from the factory is equal to 1.5 times the nominal pressure rating of the customer specified flange connection during 5 minutes.

**Connection method:**

Sanitary clamp (ISO 2825)

**Note:**

Tri-clamp® can connect except meter size 4" (100 mm).

Tri-clamp® is a registered trademark for Tri-Clover Inc.

**Principal materials:**

**Case** — Stainless steel

**Linings** — Alumina Ceramic tube

**Sanitary fittings** — 304 stainless steel (std.)

**Seal gaskets** — Silicon rubber (FDA approved)

**Note :** See Table 3 for optional materials and other related information.

**Coating** — no coating (stainless steel body)

Note) The wetted materials of LF511 detector are as follows. Do not apply this flowmeter to fluids that may corrode, deteriorate or degenerate the wetted materials. Moreover, periodical check of silicone rubber gaskets are recommended. Consult Toshiba when gasket replacement is required by negative effect by deterioration and others.

(Fluid contact materials)

- Alumina Ceramic : Linings

- 304 stainless steel(std.): Sanitary fittings

- Silicone rubber: Seal gaskets

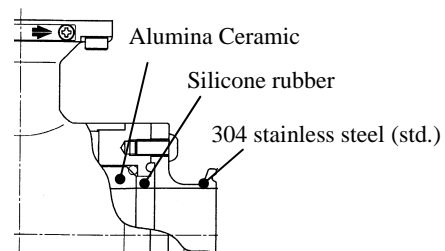

**Heat shock resistance** — for a ceramic tube detector

**Heating:**  $\Delta T \leq 302\text{ }^{\circ}\text{F} / 0.5\text{sec}$  ( $150\text{ }^{\circ}\text{C} / 0.5\text{sec}$ )

**Cooling:**  $\Delta T \leq 212\text{ }^{\circ}\text{F} / 0.5\text{sec}$  ( $100\text{ }^{\circ}\text{C} / 0.5\text{sec}$ )

**Note:** The above means that the ceramic tube detector withstands the shock of sudden heating (temperature difference **302 °F** or less per 0.5seconds) and sudden cooling (temperature difference **212 °F** or less per 0.5seconds).

**Dimensions and weights:** See Figure 3.

## ■ Model LF541 and LF546 Converter

### Input signals

#### Digital input DI

Signal type: 20 to 30Vdc voltage signal

Input resistance: 2.7 k $\Omega$

Number of inputs: one point

**DI function** — One of the following functions can be assigned to the DI signal.

**Range switching** — Selects either the higher or lower range in the unidirectional or bidirectional 2-range setting.

**Totalizer control** — Start/Stop and Reset/Start operation in built-in totalizer.

**Fixed-value outputs** — Outputs fixed-values for current and pulse outputs.

**Zero adjustment** — Executes zero adjustment (on-stream at zero flow rate).

### Output signals

#### Current output:

4–20mAdc (load resistance 0 to 750 $\Omega$ )

**Digital outputs** — 2 points are provided as standard.

#### Digital output DO1:

Output type: Transistor open collector

Number of outputs: One point

Output capacity: 30Vdc, 200mA maximum

#### Digital output DO2:

Output type: Solidstate relay output (non polarity)

Number of outputs: One point

Output capacity: 150Vdc, 150mA maximum or 150 Vac (peak to peak), 100mA maximum

**DO1 and DO2 functions** — One of the following functions can be assigned.

- **Pulse output (available only for DO1)**

Pulse rate: 3.6 to 10,800,000 pulses/hr

Pulse width: 0.3 to 500ms (but less than half of the period for 100% flow rate)

- **Multi-range selection outputs (Note 1)**

- **High-high, high, low and/or low-low limit alarm outputs (Note 2)**

- **Preset count output**

- **Converter failure alarm output (Note 2)**

**Note 1:** Two outputs (DO1 and DO2) are needed for 4-range switching and forward/reverse 2-range switching.

**Note 2:** Normal Open (default set) or Normal Close is selected for alarm outputs when programming.

**Communications output** — Digital signal is superimposed on 4–20mAdc current signal (conforms to HART protocol)

Load resistance : 240 to 750 $\Omega$

Load capacitance : 0.25 uF maximum

Load inductance : 4 mH maximum

**Note:** HART (Highway Addressable Remote Transducer) protocol is a communications protocol for industrial sensors recommended by HCF (HART Communication Foundation).

### PROFIBUS communication:

Protocol: PROFIBUS-PA

Baud rate: 31.25kbps

Bus voltage: 9-30VDC

Consumption electric current of bus: less than 16mA

Manufacture Ident-No.: 093B<sub>HEX</sub>

Standard Ident-No.: 9740<sub>HEX</sub>

Slave address: 0-126 (Default address is 126)

Profile: Profile Ver.3.01 for Process Control Devices

Function blocks: AI(Flow) $\times$ 1, Totalizer $\times$ 1

**Note:** When the PROFIBUS communication specification is selected, current output signals (DC4-20mA) are not available.

**LCD display:** 128x128 full dot-matrix LCD display (back-light provided)

**Parameter settings:** Parameters can be set by three (3) key switches at the LCD board.

The AF900 hand-held terminal is available for setting parameters from remote places.

**Note:** Products are shipped in such a status where major parameters that affect flow measurement may not be set and changed in advance for sealing specification.

**Note:** When the PROFIBUS communication specification is selected, the handheld terminal AF900 is not available.

**Counter control:** If the digital input is set for counter control, counter control is available for the integrated value and the pulse output.

**Zero adjustment:** Zero point adjustment can be started by pressing the switch in the converter.

**Damping:** 1 to 200 seconds (selectable in 1 second increments)

**“Field re-verification” Mag-Prover** – Toshiba’s Zero span calibration tools allows unit to be re-calibrated and verified using an internal software program (For more information contact Toshiba International Corp.)

**Conditions when power fails:**

Parameter setting values are stored in non-volatile memory and the values will be restored when the power returns to normal condition. The outputs and display will remain as follows when power fails.

- Current output: 0 mA
- Digital output: OFF
- LCD display: No display

**Power supply:**

- 100 to 240Vac, 50/60Hz  
(allowable voltage 80 to 264Vac)

**Surge protection:** Arresters are installed in the power supply, and current signal output circuit to help protect the meter from lightning and improve personal safety.

**Case:** Aluminum alloy

**Coating:** Acrylic resin-baked coating, pearl-gray colored

**Cable connection ports:**

**Cable glands** —

LF511/LF541 without cFMus Approval:  
Provided as standard, G(PF) 1/2 female threads, Nylon 66 material.

LF516/LF546 with cFMus Approval:  
Not provided, 1/2-14NPT male threads are required.

**Applicable diameter** — 0.433 to 0.512 inch..  
(11 to 13mm)

**Note:** The compatible outer diameter of the signal cable glands is  $\phi 6$  to 8mm for the one equipped with the PROFIBUS communication function. The power cable glands have the same compatible outer diameter ( $\phi 11$  to 13mm) as the standard size. Give a separate instruction if you need one with the standard compatible outer diameter ( $\phi 11$  to 13mm) for signal cable glands.

**Vibration resistance:**

No resonance to the following levels of vibration:

- 10 to 150Hz with acceleration of  $9.8\text{m/s}^2$
- Vibration of 30Hz with  $29.4\text{m/s}^2$  in 2h in each direction will not cause any defect to unit..

**Note:** Avoid using the flowmeter in an environment with constant vibration.

**MTBF:**

110,000 hours at 25 °C (77 °F) based on MIL-HDBK-217F

**Terminal block:** 10 poles (M4 screw)

## Installation

## ■ Dimensions

Unit : inch (mm)

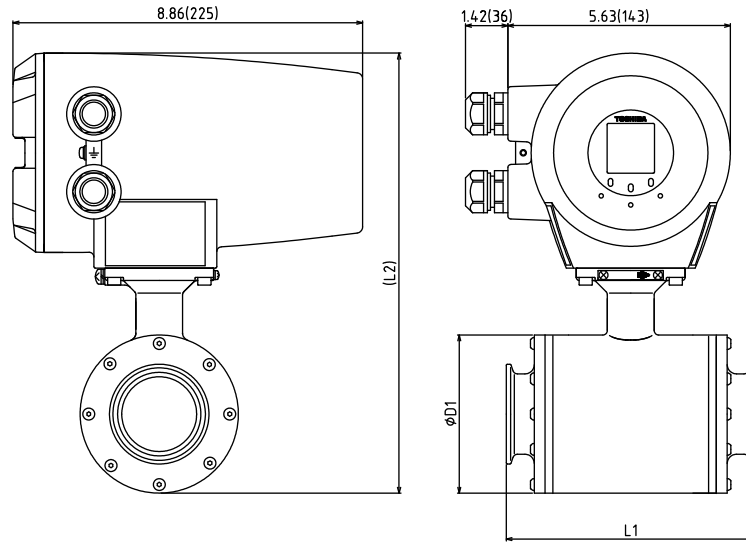

Unit:Inch

Meter size (inch)	Clamp size (ISO 2852)	L1 (inch)	(L2) (inch)	D1 (inch)	Weight (lb)
1"	1S	5.12	8.43	2.60	Approx. 12
1-1/2"	1 1/2S	5.91	10.39	3.35	Approx. 14
2"	2S	6.30	11.02	4.02	Approx. 16
3"	3S	6.69	12.05	5.00	Approx. 20
4"	4S	9.45	13.31	6.26	Approx. 34

Unit:mm

Meter size (mm)	Clamp size (ISO 2852)	L1 (mm)	(L2) (mm)	D1 (mm)	Weight (kg)
25	1S	130	241	66	Approx. 5
40	1 1/2S	150	264	85	Approx. 6
50	2S	160	280	102	Approx. 7
80	3S	170	306	127	Approx. 9
100	4S	240	338	159	Approx. 15

Note: 1 inch = 25.4mm

**Note1:** Cable glands are not provided for LF516/LF546 of cFMus approved type.  
Refer the details from the description of cable connection ports at page4 of this document..

**Figure 3. LF511/LF541 and LF516/LF546 Combined type flowmeter  
Meter sizes 1" (25mm) to 4" (100mm )**

External Connections

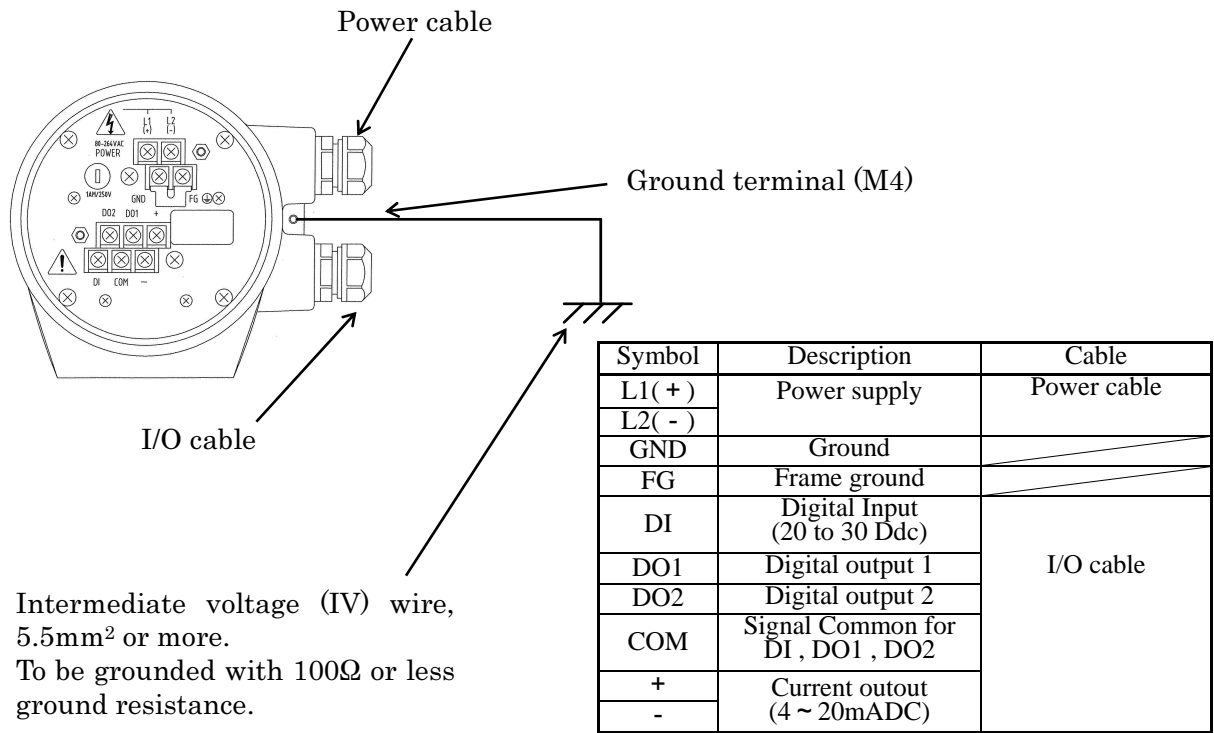

Intermediate voltage (IV) wire, 5.5mm<sup>2</sup> or more. To be grounded with 100Ω or less ground resistance.

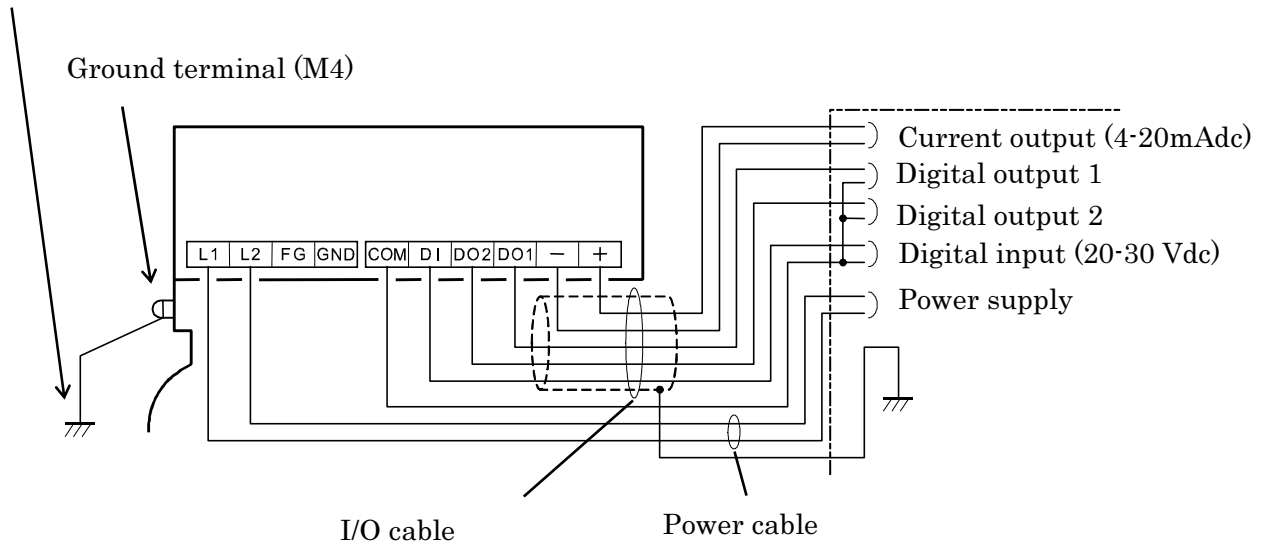

Figure 4. LF511/LF541 and LF516/LF546 flowmeter Wiring Diagram

## ■ Piping Precautions

- (1) Design the LF511/LF541 and LF516/LF546 piping to keep the filled condition inside the pipe.
- (2) The electromagnetic flow meter detector LF511-type does not have a loose mechanism. Place a loose short pipe if required.
- (3) The LF511/LF541 and LF516/LF546 requires the following straight pipe length for both upstream and downstream.

Upstream	90 degree bent pipe, T-tube, reducer or full admission condition using slice valve	L=5D
	Other valves	L=10D
Downstream	Unless the valve comes into the pipe of detector	L=0

L: Required straight pipe length -----

Straight pipe length plus half length of detector.

D: Nominal diameter.

- (4) Design piping so that the liquid pressure does not exceed the standard flange pressure.
- (5) Select one from the size, length and quantity of the compatible bolts and nuts are different depending on the bore diameter and the flange specification.
- (6) Insulate piping so that the temperature around the transformer may not exceed 50°C when the high-temperature fluid passes.

## ■ Wiring Precautions

- (1) Connect the grounding wire (IV wire 5.5mm<sup>2</sup> or more) to a good earth ground (100 ohm or less ground resistance). Make the wire as short as possible. Do not use a common ground shared with other equipment where earth current may flow. An independent earth ground is recommended.
- (2) DO1, DO2, and DI use the same common terminal (COM). This COM cannot be connected to other equipment which have their own ground terminal.  
(Power supply for connecting to DI or DO, etc...) Need to wire separately.

## ■ Meter Size

### To select the meter size:

See Figure 5 and find meter sizes within the velocity of 1.64 to 32.8 ft/s (0.5 to 10 m/s) for a specified full-scale (measuring range high limit) flow.

- When the fluid conductivity is 1 uS/cm or smaller, the maximum flow velocity becomes 32.8 ft/s (10 m/s) or slower. Need to confirm its availability by referring to this figure.
- Make sure the full-scale flow rate used for the final planning stage stays within 32.8 ft/s (10 m/s) in terms of flow velocity.

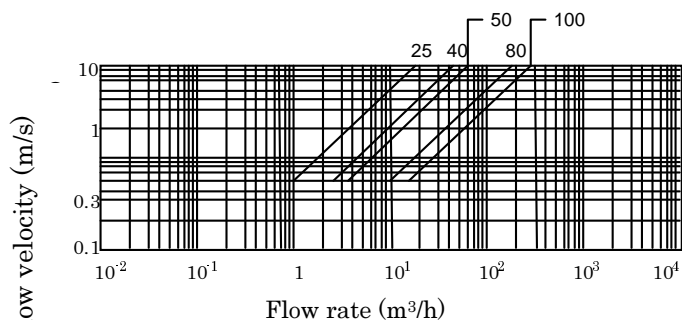

**Table 1. Flow rate and Flow velocity (English Unit)**

Unit: gal/min

Meter size	Flow rate		
	1.64 ft/s	3.28 ft/s	32.8 ft/s
1	3.900	7.780	77.80
1-1/2	9.953	19.91	199.1
2	15.55	31.12	311.2
3	39.81	79.65	796.5
4	62.22	124.5	1245

**Table 2. Flow rate and Flow velocity (SI Unit)**

Unit: m<sup>3</sup>/h

Meter size (mm)	Flow rate		
	0.5 m/s	1 m/s	10 m/s
25	0.884	1.767	17.67
40	2.262	4.523	45.23
50	3.534	7.067	70.67
80	9.045	18.09	180.9
100	14.14	28.27	282.7

## Ordering Information

1. When ordering the LF511/LF541 and LF516/LF546 flowmeter, refer to Tables 3 and 5 (Type Specification Codes).  
An entry must be made for each of the columns in each of these tables.
2. Fluid characteristics:
  - (1) Type of fluid to be measured and its characteristics
  - (2) Fluid temperature
  - (3) Fluid pressure
  - (4) Electrical conductivity of the fluid
3. Measuring range
4. I/O function setting
5. Ordering scope:  
Flow calibration data: (required or not)
6. Other items:  
Specifications other than standard items

**Consult Toshiba before ordering when choose material of grounding ring.**



**Table 3. Specification Code (Capacitance type LF511 detector (Sanitary type))**

Model					Specification Code										Description	Category		
1	2	3	4	5	6	7	8	9	10	11	12	13	14					
L	F	5	1	1											Detector of Capacitance type Electromagnetic Flowmeter			
L	F	5	1	6											cFMus Hazardous location certificate type (Note4)			
					E										Meter size 1" (25mm)	•		
					F										1 1/2" (40mm)	•		
					G										2" (50mm )	•		
					H										3" (80mm)	•		
					J										4" (100mm)	•		
						L									Mounting Style Detector/Converter combined type (LF511/LF541) (LF516/LF546)	•		
							A								Connection method (Note 1) Sanitary clamp (ISO 2825)	•		
								A							Application Standard	•		
									A						Lining Material Ceramic tube	•		
										B					Plumbing joint materials 304 stainless steel	•		
										G							316 stainless steel	○
											D				Flow and calibration velocity range / with or without designated setting item Standard range calibration / without designated setting item	•		
											E						Specified range calibration	○
											F						Standard range calibration / with designated setting item	○
												A			Standard			
													A		Coating No coating	•		
													Z	Other (Note 2)			○	

Code explanation: ●: Standard, ○: Option

**Note1:** When connected to the partner pipe, please refer to the Figure 5.

Size of Ferrule and Clamp please refer to the Table 4.

Piping joint product (Ferrule, Clamp, Gasket) please use an ISO supported product.

**Note2:** In case of cord "Z", please refer beforehand.

**Note3:** The type of material used is alumina ceramic, this is suitable for both acid and alkali liquids.

This ceramic lining is held with seals, there are two types, one for acids, and the other for alkalis.

**Note4:** Cable glands are not provided. Refer to the part of "Cable connection port" at detector and converter.

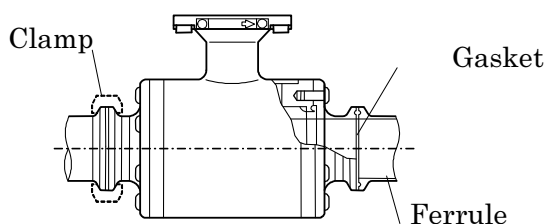

Fig.5 Name of piping joint product

Table 4. Joint size

Meter size	Clamp size	Ferrule
25mm(1S)	1S	
40mm(1 1/2S)	1 1/2S	
50mm(2S)	2S	
80mm(3S)	3S	
100mm(4S)	4S	

**Table 5. Specification Code for converters)**

Model					Specification Code									Description	
1	2	3	4	5	6	7	8	9	10	11	12	13	14		
L	F	5	4	1											Combined Converter of Capacitance type Electromagnetic Flowmeter
L	F	5	4	6											Combined Converter of Capacitance type Electromagnetic Flowmeter with cFMus Hazardous location certificate
					A										Usage LF540 for General purpose
						A									Mounting Structure Detector/Converter combined type
							B								Display LCD display provided
								2							Output 4-20mA dc current, 2 points DO and 1 point DI provided.
									1 2						Communications function Current output + HART communication PROFIBUS communication (Note1)
										1					Power supply 100 to 240Vac, 50/60Hz
											A Z				Coating Acrylic resin-backed coating, pearl-gray colored Other (option)
												A A			Standard

Note 1: When PROFIBUS communication is provided, current output(4-20mA) and HART communication cannot be used.  
Refer Table6 for more details.

**Table 6. Communication functions and output selection table**

Selection of Function		Availability of outputs			
Code (10 <sup>th</sup> digit)	Selected Communication	4-20mA dc	DO1	DO2	DI
1	HART	✓	✓	✓	✓
2	PROFIBUS	X	✓	✓	✓

Code explanation: ✓:Available X:Not Available

ISO9001 and ISO14001 are certified.

Specifications are subject to change without notice.

Printed in Japan 2017-7(TBLS)



Misuse of this product can result in damages to property or human injury.  
Read related manuals carefully before using this product.

© Toshiba Infrastructure Systems & Solutions Corporation

2017

All Rights Reserved.