

Introduction

The LF502 electromagnetic flowmeter uses Faraday’s Law of electromagnetic induction in the same way as conventional electromagnetic flowmeters to measure the flow rate. Position of electrodes in the LF502 is so designed that it can be used even in a partially-filled pipe to measure the flow rate.

Improved functional magnetic field distribution technique enables a high-precision flow measurement continually from low-level to fully-filled flow conditions. This eliminates unnecessary piping work such as lifting the downstream pipe section to fill the detector pipe.

Compared with flowmeters measuring the flow rate by means of flow level, the obstructionless LF502 flow-meter does not usually allow mud, sands and other solid sediment stay at the bottom of the detector pipe and is unaffected by wave or floating solids on the fluid surface.

The AF900 hand-held terminal (HART*¹ communicator) can be used to communicate with the flowmeter from a remote place.

*1: HART protocol (Highway Addressable Remote Transducer) is a communication protocol for industrial sensors recommended by the HCF (HART Communication Foundation).

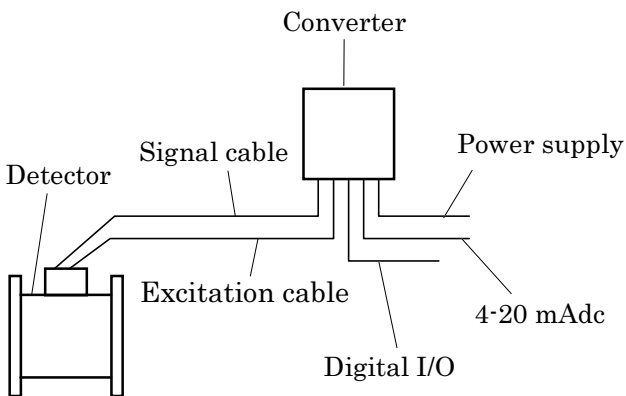

Figure 1. LF502/LF232*F Configuration



Figure 2. LF502 Electromagnetic Flowmeter for Partially-filled Pipes

Specifications

Overall Specifications

Measurement range:

Meter size	Measurement range
6" (150mm)	0 – 264 GPM(std) to 0 – 1320 GPM (0 – 60 m ³ /h to 0 – 300 m ³ /h)
8" (200mm)	0 – 484 GPM(std) to 0 – 2420 GPM (0 – 110 m ³ /h to 0 – 550 m ³ /h)
10" (250mm)	0 – 770 GPM(std) to 0 – 3850 GPM (0 – 175 m ³ /h to 0 – 875 m ³ /h)
12" (300mm)	0 – 1100 GPM(std) to 0 – 5500 GPM (0 – 250 m ³ /h to 0 – 1250 m ³ /h)
14" (350mm)	0 – 1540 GPM(std) to 0 – 7700 GPM (0 – 350 m ³ /h to 0 – 1750 m ³ /h)
16" (400mm)	0 – 1980 GPM(std) to 0 – 9900 GPM (0 – 450 m ³ /h to 0 – 2250 m ³ /h)
20" (500mm)	0 – 3124 GPM(std) to 0 – 15620 GPM (0 – 710 m ³ /h to 0 – 3550 m ³ /h)
24" (600mm)	0 – 4400 GPM(std) to 0 – 22000 GPM (0 – 1000 m ³ /h to 0 – 5000 m ³ /h)

Note: Above flow rate is almost 0 – 3.28 ft/s (std) to 0 – 16.4 ft/s (0 – 1 m/s to 0 – 5 m/s) flow velocity.

Fluid-level range:

Meter size	Specification
6" to 12" m (150 to 300m)	1-1/4"(30mm) to fully-filled condition.
14" to 24" (350 to 600mm)	10% of inside tube diameter to fully-filled condition.

Note: The fully-filled condition means a 100% of inside tube diameter.

Accuracy: ±2% FS (when measurement range is standard)

Note: The accuracy is measured under standard operating conditions at Toshiba's calibration facility.

Required straight pipe length:

10D minimum on upstream side and
5D minimum on downstream side

Note: D is a nominal meter size.

Fluid conductivity: 100µS/cm minimum

Fluid temperature: 32 to 131 °F (0 to 55 °C)

Ambient temperature: 14 to 122 °F (-10 to 50 °C)

Dimensions and Weights: See figures 3 to 5.

Power supply:

100 to 120 Vac (80 to 132 Vac), 50/60Hz

Power consumption: 50VA (30W) or less

■ Model LF502 Detector

Meter sizes: 6" (150 mm), 8" (200 mm), 10" (250 mm), 12" (300 mm), 14" (350 mm), 16" (400 mm), 20" (500 mm), 24" (600 mm)

Fluid pressure:

0 psi or 0 bar (0 MPa) to the pressure limited by flange standard
(fully-filled condition)

Connection flange standards:

ANSI 150, JIS 10K

Structure:

Standard — IP67 and NEMA 4X Watertight

Option — IP68 and NEMA 6P Submersible type allows for accidental submergence up to 15m for 48hours.

Coating: Phthalic acid resin coating, pearl-gray colored (standard for watertight type) or black tar epoxy (option for watertight type and specified exclusively for submersible type)

Principal materials:

Case — carbon steel

Measuring pipe — 304 stainless steel

Linings — The following are the standards:

Meter size	Standard specification
6" to 16" (150 to 400mm)	EPDM rubber
20" & 24" (500 & 600mm)	Chloroprene rubber

Electrodes — 316L stainless steel (std.)

Grounding rings — The following are the standards.

Meter size	Standard specification
6" to 16" (150 to 400mm)	316 stainless steel
20" & 24" (500 & 600mm)	304 stainless steel

See Table 1 for optional materials and other related information.

Coating: phthalic acid resin coating (std.),
Pearl-gray colored

Cable connection port:

Cable glands: Provided as standard, R(PT) 1/2 male screw.

Applicable diameter: 0.433 to 0.512 inch (11

■ Model LF232 *F converter

Input signals

Analog signal — the voltage signal from detector, proportional to process flow rate.

Digital input DI (opt.)

(added when 9th digit of specification code is "3")

Voltage level: High level 20 to 30 V dc

Low level 2 V dc or less

Input resistance: 2.7 k Ω

Number of inputs: 2 points (DI1 and DI2)

DI functions:

For digital input function, either of the following functions can be selected.

• Range switching

One Digital Input is used : switching between large and small ranges of forward/reverse, 2-range measurement.

Two Digital Inputs are used : switching between ranges of single direction, 4-range measurement.

• Totalizer control input

Totalizer Start/Stop control or Reset/Start

• Output hold input

Fixed with set value for current output and pulse output (loop check)

• Zero adjustment

Starts zero adjustment (on-stream at zero flow rate) when DI voltage level goes low after remaining high for 10 to 20 seconds.

Output signals

Current output:

4–20mA dc (load resistance 0 to 1K Ω)

Digital output (DO) — One point (std.) and three more point is optionally available as follows.

Digital output DO1 (std.):

Output type : Transistor open collector

Number of outputs : One point

Output capacity : 30Vdc, 200mA maximum

Digital output DO2~DO4 (opt.)

(added when 9th digit of specification code is "3")

Output type : Solidstate relay output (non polarity)

Number of outputs: 3 points

Output capacity : 150Vdc, 150mA maximum or 150Vac (peak to peak), 100mA maximum

DO functions—Four digital output function, either of the following functions can be selected.

• Totalizer pulse output

DO1 or DO2 can be selected (Forward direction pulse and reverse direction pulse can be assigned

independently)

In the case of DO1

Pulse rate: 3.6 to 3,600,000 pulses/h

Pulse width: Settable within the range of 0.3 to 500ms

In the case of DO2

Pulse rate: 3.6 to 360,000 pulses/h

Pulse width: Settable within the range of 4 to 500ms

• Range switching output

One Digital Output (DO) is used

• Single direction, 2-range switching signal

• Forward/reverse direction switching signal

Two Digital Outputs (DO) are used

• Single direction, 4-range switching signals

• Forward/reverse 2-range switching signals

• High/low limit alarm output

An alarm is output when flow rate goes above or below the set-point value

Setting range : -10 to 110% of the settable maximum range

High limit 2 points, low limit 2 points can be set

At the time of alarm output, Normally Open or Normally Closed contact can be selected

• Preset point output

Contact ON when totalizer count exceeds the set value

Setting range : 1 to 99999999 count

• Converter error alarm

An alarm is output when an operation error is detected by self-diagnosis.

At the time of alarm output, Normally Open or Normally Closed contact can be selected

Communications signal:

A digital communications (HART protocol) signal is superimposed on 4 to 20 mA dc analog output signal.

Load resistance: 240 Ω to 1 k Ω

Load capacitance: 0.25 μ F or less

Load inductance: 4mH or less

(For maximum cable length, about 2km is a guideline length when CVV-S 1.25mm² is used under standard installation condition.)

Note: HART (Highway Addressable Remote Trans-ducer) is a communications protocol for industrial sensors recommended by the HCF (HART Communication Foundation).

Output display:

16-character \times 2-line dot-matrix LCD

(with back light).

2 units can be selected from the flowing units: flow velocity, instantaneous flow rate, total flow (forward/reverse/difference flow), total count, %, custom unit.

Parameter settings—Parameters can be set as follows

- IR Switches:** Various parameters can be set without opening the converter housing using 4 infrared switches (password can be set)
 - Zero adjustment:** Zero point adjustment can be started by pressing the switch in the converter.
 - Digital communication:** The AF 900 hand-held terminal is needed to set parameters.
 - Damping:** 0.5 to 60 s (selectable in 1s increments)
- “Field re-verification” **Mag-Prover** – Toshiba’s Zero span calibration tool : Allows unit to be re-calibrated and verified using internal software program (for more information contact Toshiba International Corp.)

Conditions when power fails:

The output and display will stay as follows when power fails. Parameter setting values are stored in non-volatile memory and the values will be restored when the power returns to normal condition.

- Current output: 0 mA
- Digital output : OFF (contact open)
- LCD display : No display

Surge protection: Surge protectors are installed in the power supply, excitation circuit, current signal output and digital I/O circuit.

Terminal block structure:21-pole, screw connection type (M4 screw)

Housing: Aluminum alloy

Coating: Acrylic resin-baked coating, pearl-gray colored

Cable connection ports :

- A cable gland is provided for each port.
- OD of cable ϕ 11 to 13 mm
- Material Nylon 66
- G(PF) 1/2 male screws.

Structure: IP67 and NEMA 4X Watertight

Vibration resistance:

- No resonance point exists when the following vibration is applied:
- 10 to 55Hz with amplitude of 0.07mm,
- No problem occurs when vibration of 30Hz, 29.4m/s² is applied in each direction for 4 hours each.

Note: If the flowmeter is intended to be used in a location where vibration is applied constantly contact Toshiba.

Dimension and Weights:

See Figure 5

Installation

■ **Dimensions**
Separate type LF502

Unit: inch (mm)

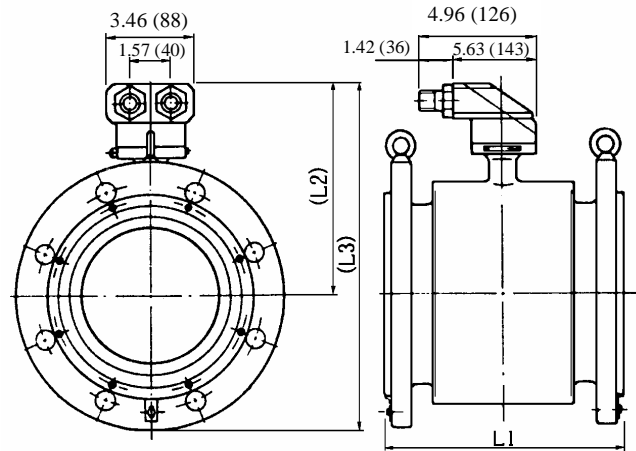

Figure 3. Detector Dimensions for Meter Sizes 6" (150 mm) and 8" (200 mm)

See the following tables for dimensions of L1, L2 and L3 in Figure 3 above, and the number of bolts required for each flange.

ANSI 150 flange dimensions:

Meter Size (inch)	L1 (inch)	L2 (inch)	L3 (inch)	No. of bolts	Weight (lb)
6	10.47	9.67	15.14	8	Approx. 84
8	11.81	10.69	17.42	8	Approx. 194

JIS 10K flange dimensions:

Meter Size (mm)	L1 (mm)	L2 (mm)	L3 (mm)	No. of bolts	Weight (kg)
150	266	246	386	8	Approx. 35
200	300	271	436	12	Approx. 80

■ **Dimensions**
Separate type LF502

Unit: inch (mm)

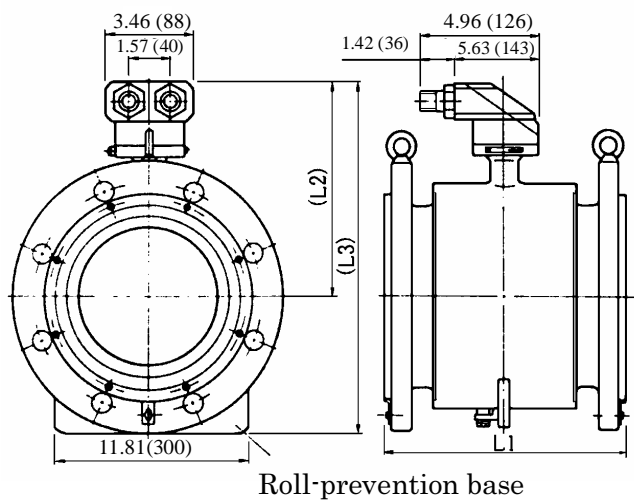

**Figure 4. Detector Dimensions for Meter Sizes
 10" (250 mm) to 24" (600 mm)**

See the following tables for dimensions of L1, L2

and L3 in Figure 4 above, and the number of bolts required for each flange.

ANSI 150 flange dimensions:

Meter Size (inch)	L1 (inch)	L2 (inch)	L3 (inch)	No. of bolts	Weight (lb)
10	13.78	12.05	20.05	12	263
12	15.75	12.95	22.45	12	318
14	17.72	13.74	24.24	12	359
16	19.69	15.12	26.87	16	476
20	23.62	16.42	30.17	20	527
24	23.62	18.46	34.46	20	701

JIS 10K flange dimensions:

Meter Size (mm)	L1 (mm)	L2 (mm)	L3 (mm)	No. of Bolts	Weight (kg)
250	350	306	506	12	Approx. 110
300	400	329	551	16	Approx. 120
350	450	351	596	16	Approx. 130
400	500	386	666	16	Approx. 180
500	600	403	740	20	Approx. 190
600	600	455	852	24	Approx. 250

■ Dimensions

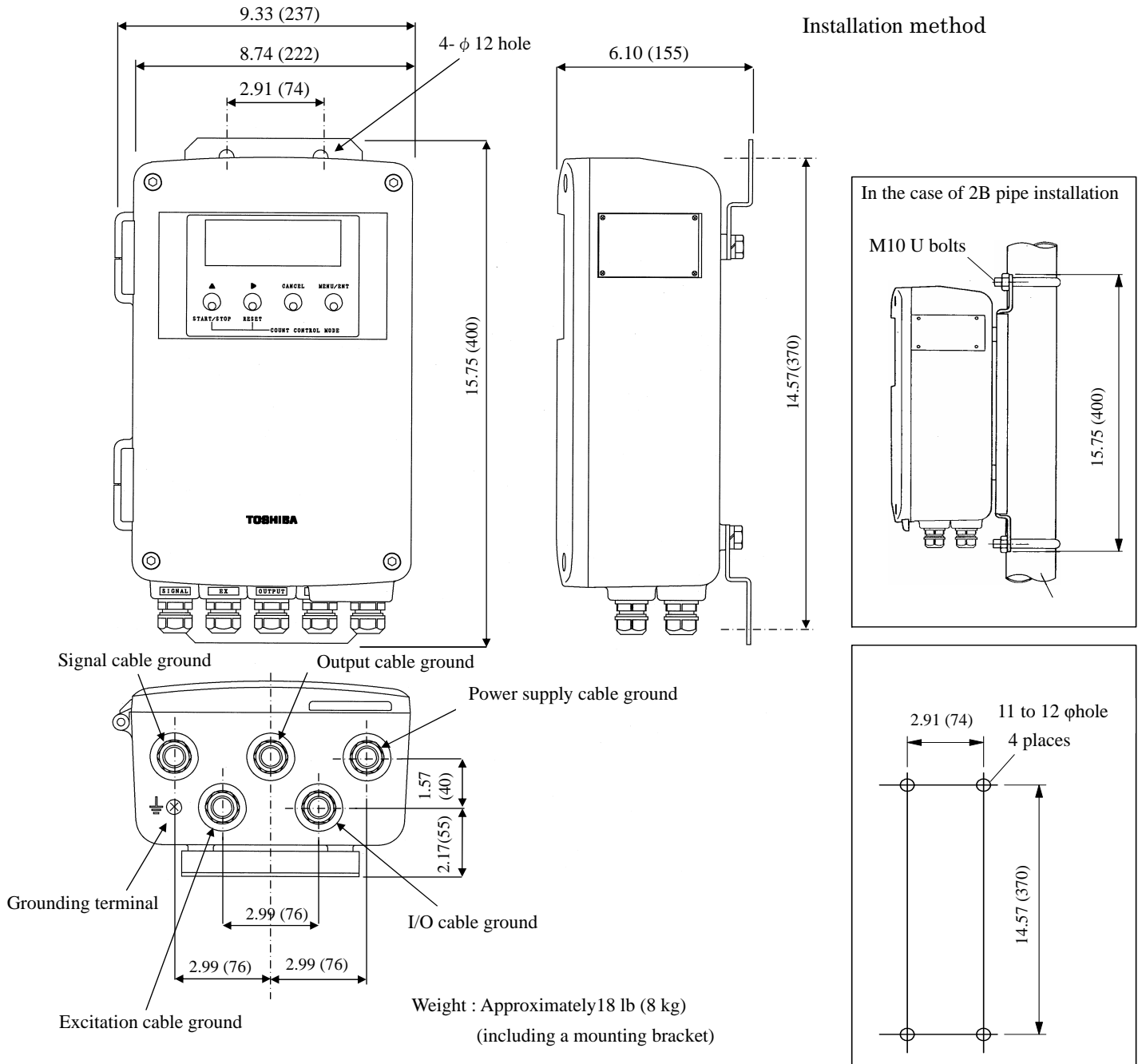

Figure 5. Separate type converter LF232 *F

External Connections

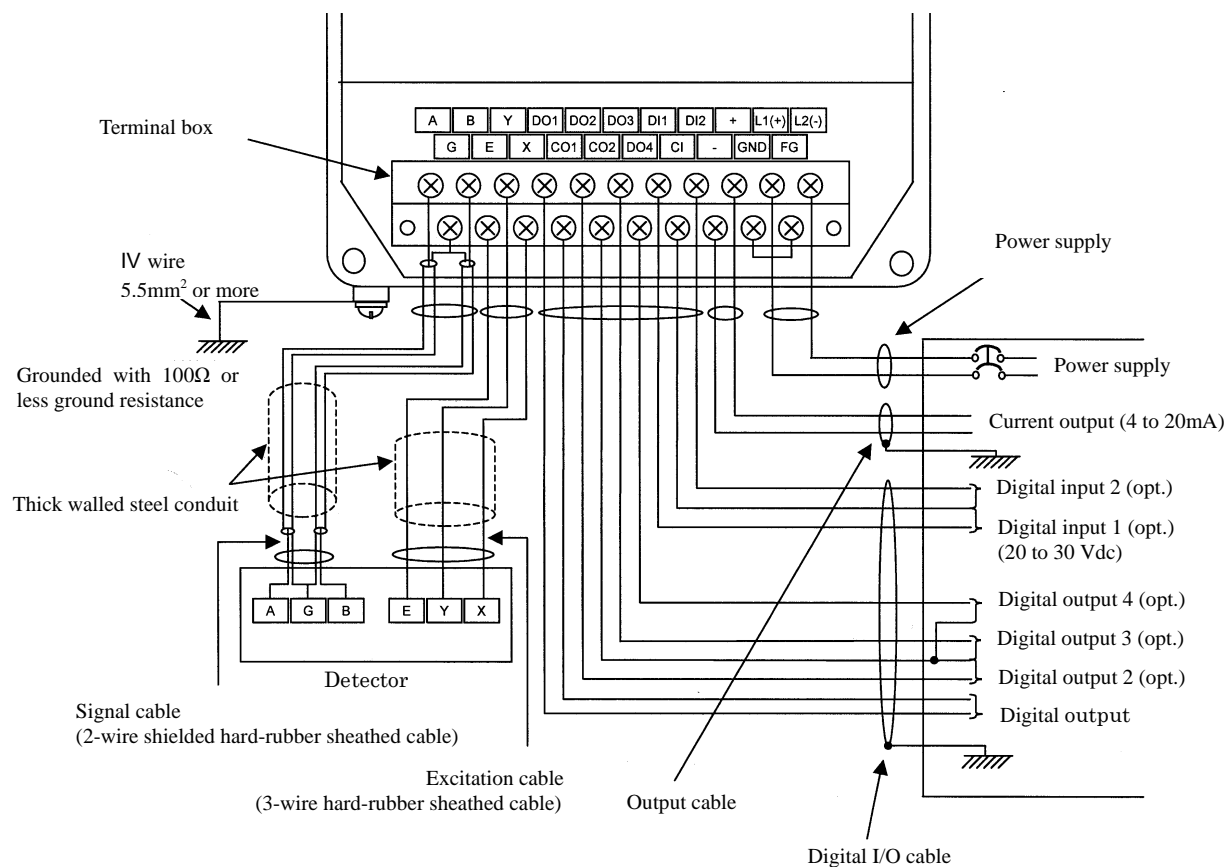

Figure 6. LF502/LF232 *F flowmeter Wiring Diagram

Wiring Precautions

- (1) Be sure to use thick walled steel conduit (22 mm) for signal and excitation cable wiring between the detector and converter. The conduit screw is R(PT)1/2. Use flexible conduits at the cable outlets of the detector as needed.
- (2) Make the grounding wire as short as possible. Do not use a common wire shared with other equipment where earth current may flow. An independent earth ground is recommended.
- (3) The meter may affect its accuracy when the electric potential of measurement fluid is unstable condition.

- Make the piping of the upstream side and downstream side the same material.
- When the material of next pipes are conductive like metal, use a 5.5mm² or larger core cable for grounding of detector and wire it at 2 places as follows.
 - Between Grounding terminal at detector body and Grounding ring at upstream side.
 - Between Grounding terminal at detector body and Grounding ring at downstream side.

- When the material of next pipes are non-conductive like plastic, use a 5.5mm² or larger core cable for grounding of detector and wire 1 place as follows.
 - Between Grounding terminal at detector body and Grounding (100 ohm or less).
- (4) DO1 to DO4 and DI1 to DI2 use the same common terminal (COM). This COM can not connect to other instruments that have their own ground terminal (Power supply for connecting to DI or DO, etc...). Need to wire separately.

■ Piping Precautions

(1) Flange connection

The flowmeter has upstream and downstream flanges on the ends of detector pipe. Connect these flanges with the flanges on both sides of pipeline bore using connection bolts after inserting a gasket between them. See Figure 7. Tighten the bolts in even increments diagonally across.

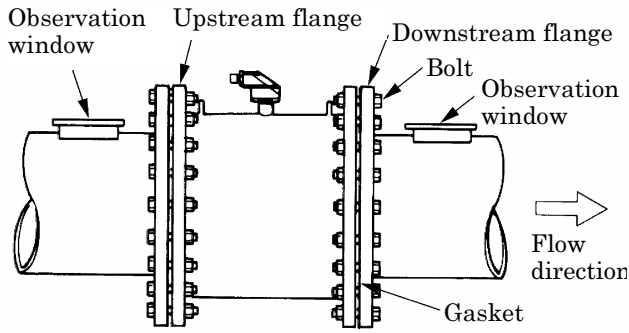

Figure 7. Flange Connection ■

(2) Required straight pipe length

The straight pipe length is required to prevent uneven flow velocity and a disturbance on the fluid surface in the detector pipe. The required straight pipe length should be as follows:

- Downstream side: $L = 5D$ minimum
- Upstream side: $L = 10D$ minimum

where,

L = straight pipe length (straight pipeline length + half length of detector pipe length)

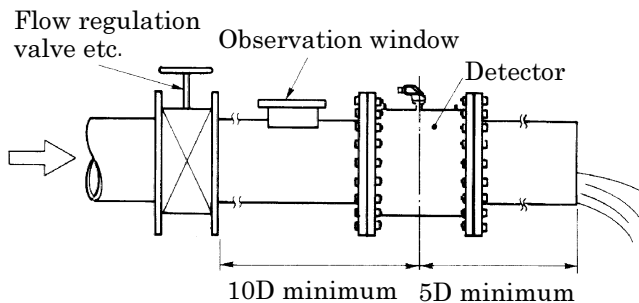

Note: The length of reducers, if used, can be counted as a part of straight pipe length.

Figure 8. Required Straight Pipe Length on Upstream and Downstream Sides

■ About establishment environment

Do not store or install the flowmeter in:

- Places where there is direct sunlight.
- Places where excessive vibration or mechanical shock occurs.
- Places where high temperature or high humidity conditions obtain.
- Places where corrosive atmospheres obtain.
- Places submerged under water.
- Place where there is slop floor. To put the flowmeter temporarily on the floor, place it carefully with something, such as stopper, to support it so that the flowmeter will not topple over.

In places like the following places, there is the case that infrared switches do not function correctly. (If this is unavoidable, use an appropriate cover.)

- Places where gets very bright light onto operation panel. (direct sunlight, reflection light of sunlight by windowpanes, diffused reflection light of strength etc.)
- Places where smoke and steam occur near.
- Places where a snow, ice or mud that may attached.

■ Ordering Information

1. When ordering the LF502 flowmeter, refer to Table 1 (Type Specification Codes). An entry must be made for each of the columns in each of these tables.
2. Fluid characteristics:
 - (1) Type of fluid to be measured and its characteristics
 - (2) Fluid temperature
 - (3) Fluid pressure
 - (4) Electrical conductivity of the fluid
3. Measuring range
4. Digital I/O specifications
5. Ordering scope:
 - (1) Actual flow calibration data: (required or not)
6. Other items
 - Specifications other than standard items

Table 1. Specification Code for LF502 detector

Model					Specification Code							Description	Size			
1	2	3	4	5	6	7	8	9	10	11	12		A	B		
L	F	5	0	2										LF502 Electromagnetic flowmeter		
					K									Meter size		
					L									6" (150mm)	●	-
					M									8" (200mm)	●	-
					N									10" (250mm)	●	-
					P									12" (300mm)	●	-
					Q									14" (350mm)	●	-
					R									16" (400mm)	●	-
					S									20" (500mm)	-	●
						A								24" (600mm)	-	●
							A							Standard	●	●
								C						Connection flange standard		
								J						ANSI 150	●	●
														JIS 10K	●	●
									C					Lining		
									D					Chloroprene rubber	-	●
									T					EPDM rubber	●	○
														Teflon PFA	○	-
										B				Electrode and Grounding Ring Material		
										C				316L stainless steel + 316 stainless steel	●	○
										F				Titanium + Titanium	○	○
										H				Hastelloy C + Hastelloy C	○	○
														316L stainless steel + 304 stainless steel	○	●
										A				Flow and calibration velocity range		
														Standard range calibration	●	●
														Coating		
										B				Phthalic acid resin	●	●
										C				Black tar epoxy resin , thickness 0.3mm	○	○
										D				Black tar epoxy resin , thickness 0.5mm	○	○
										E				Black tar epoxy resin , thickness 0.5mm (for submersible type)	○	○

Code explanation: ●: Standard ○: Option —: Not available

Size groups

A : 6" (150mm) to 16" (400mm)

B : 20" (500mm) and 24" (600mm)

Table 2. Specification Code for LF232 *F converter

Model					Specification Code							Contents	LF232 type		
1	2	3	4	5	6	7	8	9	10	11	12				
L	F	2	3	2										Separate type converter	
						A								Purpose	
														Standard	●
							F							Compatible detectors	
														For Partially-filled pipes (Meter size : 150mm(6") to 600mm(24"))	●
										C				Mounting nuts and bolts	
										E				Panel, wall mounting (material : 304 stainless steel)	●
														Pipe mounting (material : 304 stainless steel)	○
											1			Digital input/output	
														Current output	●
											3			+ Digital output points (1 point)	
														Current output	○
														+ Digital output points (4 points) + Digital input points (2 points)	
											1			Communication function	
														HART communication	●
											1			Power supply	
														100Vac-120Vac, 50/60Hz	●
												A		Standard	●

Code explanation: ●: Standard ○: Option

ISO9001 and ISO14001 certified.



Misuse of this product can result in damages to property or human injury.
Read related manuals carefully before using this product.

Specifications are subject to change without notice.

Printed in Japan 2017-7 (TBLS)

©Toshiba Infrastructure Systems & Solutions

Corporation 2017,

All Rights Reserved.