



The trend toward open networks that allow integrated operation of different computer systems has spurred technological advances in desktop computers and networks. These, in turn, have contributed to business process re-engineering and the downsizing of information systems. In addition, information exchange through the Internet is steadily expanding among both businesses and individuals. In the field of mobile communications, use of car phones and portable cellular phones is growing worldwide. Toshiba is a leading provider of these and other information and communication systems for multimedia applications.

Digital Terrestrial Broadcasting Transmitter for Wide Area Field Test in Japan

A digital terrestrial broadcasting system is expected to serve as an advanced broadcasting medium supporting high definition TV (HDTV), multi-channel TV and high speed data broadcasting. It is also expected to provide mobile reception service and good quality pictures because of its robustness against multi-path and fading.

In the US and UK, commercial digital terrestrial broadcasting service was started in Autumn last year. Also, wide area field testing for digital terrestrial broadcasting has started in the Tokyo area of Japan last Autumn.

With the experimental digital broadcasting station installed in Tokyo Tower, Toshiba developed and delivered a new type of high power digital transmitter for digital broadcasting field testing.

In a digital broadcasting system, the distortion caused by high power amplifier non-linearity must be lower than that of analog transmitters. The digital transmitter developed by Toshiba exhibits very low non-linear distortion at -35dB or less intermodulation ratio with 500W output power.

Several kinds of field tests were completed, with the experimental station: evaluation test for fixed reception, mobile reception and SFN (Single Frequency Network) performance.

Also, several kinds of broadcasting service tests started from April this year.



High power transmitter for digital terrestrial broadcasting

TPC-5 CN and TAT-12/13 CN, WDM Upgrade for Optical Submarine-Cable Networks

With the demand for international telecommunication increasing due to rapid growth of the Internet etc., the expansion of transoceanic cable system capacity has been advancing rapidly.

Toshiba contributed to the realization of commercial transoceanic cable networks, such as TPC-5 CN (presided by KDD and AT&T), and TAT-12/13 CN (presided by AT&T, BT and France Telecom) by utilizing a ring network configuration technology for optical-fiber submarine cable systems. The systems were put into commercial service in 1995.

To cope with the increasing demand for capacity expansion, as stated above, system upgrades using wavelength division multiplexes (WDM) technology have been planned. For this, Toshiba has provided NPE (Network Protection Equipment) capable of network reconfiguration by the "self healing" function against network failures, and associated NME (Network Management Equipment) to six submarine cable landing stations in TPC-5 CN and four stations in TAT-12/13 CN.

These system upgrades are currently in their final stages.

Upon completion of system upgrades, final capacity will be expanded up to 10 Gbps (formerly 5 Gbps) for TPC-5 CN and 15 Gbps (formerly 5 Gbps) for TAT-12/13 CN.

These upgraded systems (both TPC-5 CN and TAT-12/13 CN) are expected to be put into commercial service in 1999.



Network protection equipment for optical submarine cable network

MAGNIA™ Series Global Network Server

For the sake of rapid progress of network operating system, the reliability and performance of PC-servers are becoming increasingly important. Toshiba has, from the beginning, emphasized high reliability in its development concept, and that concept has been continued in the GS series with the original server management sub-system.

Fiscal 1998 saw the overseas debut of Toshiba's PC-Server. Toshiba, in its drive to increase sales, changed the appearance, design of the product and named the product to MAGNIA™ series.

The line encompasses three types: MAGNIA™ 3000, 5000 and 7000. Toshiba also developed extension disk units. They are identical for both domestic and overseas models.

In addition to ordinary functions of GS series such as redundant power supplies and hot swapping disks, Toshiba also developed a more progressive hardware management system, redundant LAN support and redundant fans. Toshiba also developed server component modules which offer not only wider user accessibility but also easier access.

Toshiba's highest model, the MAGNIA™ 7000 adopts Xeon 450 MHz, with four CPUs at maximum configuration. Further, in its disk sub-system, Toshiba adopted the high performance RAID (Redundant Array of Inexpensive (Independent) Disks) controller, Ultra-2, as its interface, and HDDs spinning at 10,000rpm.

"Xeon" is a trademark of Intel Corporation.



MAGNIA™ 3000 tower



MAGNIA™ 5000/7000 rackable equipment



Rack model for large-scale system (MAGNIA™ 5000/7000)

Baseband Chipset for GSM Terminal

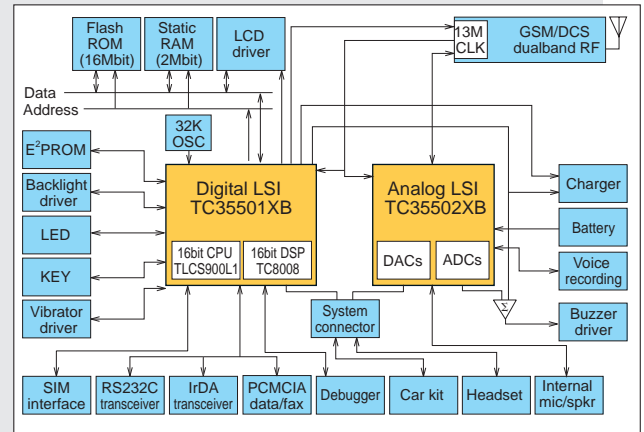

Typical terminal architecture based on the Toshiba baseband chipset

The global system of mobile communications (GSM) has found acceptance in more than 110 countries and regions, and it is today the most successful wireless communication system worldwide. Toshiba, one of the world's largest manufacturers of electronic components, and offering a wide range of products for digital mobile communication systems, has developed a baseband chipset for GSM terminals.

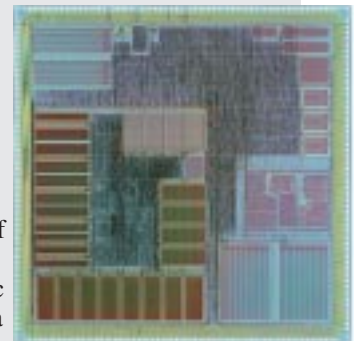

GSM digital baseband LSI

It consists of digital baseband LSI TC35501XB and analog baseband LSI TC35502XB, which offer the following features:

- Dualband functions of GSM 900MHz and DCS 1800MHz
- Triple mode speech codec of Full Rate, Enhanced Full Rate and Half Rate
- Low current consumption paging
- Embedded 16bit CPU TLC900L1 and 16bit DSP TC8008
- High speed SIM card interface
- IrDA infrared and data/fax interface
- Space saving with FBGA slim packages

DOCSIS (MCNS Standard) Cable Model

Toshiba's DOCSIS 1.0^{*1} cable modem, PCX1000, was the world's first to be certified by CableLabs^{*2} in March 1999. The honor was given to only two vendors out of nine.

DOCSIS 1.0 is the defacto standard of cable modems, made by MCNS^{*3}, a cable industry consortium. Before DOCSIS 1.0, several vendors, including Toshiba, had been providing proprietary cable modem systems which were not compatible with each other. End users could then buy DOCSIS modems at retail stores like telephone-line modems, providing easy access and much higher speed data communications, such as for internet access.

Toshiba first provided the cable modems to the North American market, followed by the Japanese market, and is now also considering deployment in Southeast Asia.

MCNS is now preparing a set of advanced specifications, called DOCSIS 1.1, which enhances quality of service and security functions. Toshiba is currently developing its DOCSIS 1.1 modems as well, for contributing to the growth of data communication services in the CATV world.

*1 Data Over Cable Service Interface Specification

*2 A laboratory founded by North American CATV operators

*3 Multimedia Cable Network System Partners



DOCSIS (MCNS standard) cable model

Process Control and Monitoring Systems for Shikoku Brewery of ASAHI BREWERIES LTD.

Shikoku Brewery of ASAHI BREWERIES LTD. in June 1998 became the first brewery in the Shikoku district. For this brewery, Toshiba supplied the process control and monitoring systems for brewing, packaging and utilities, the logistics system for the receipts and shipment of products, and the fuel cell.

<Process Control and Monitoring Systems>

Using FA3100TM as an industrial personal computer (PC) with general graphical user interface (GUI) and general programmable logic controllers (PLCs), Toshiba provides high level automation through such functions as automatic plant start-up and so on. These functions reduce the number of operators below that needed for conventional operations.

<Logistics system>

The UX7000/E3000TM offers such functions as intentional management for the vehicle routing planning, management of warehouse stock and truck guidance. This system enables highly efficient receiving and the shipping.

<Fuel Cell>

Fuel Cells provide clean energy that is gentle to the environment by effectively using methane gas (CH₄) resulting from disposal of factory wastes.



Central monitoring system

TOSTEEL-NT™ Plant Control System Platform on Windows NT®

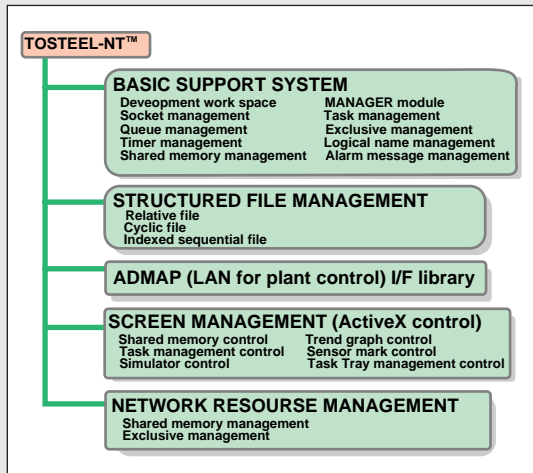

Configuration of TOSTEEL-NT™

WindowsNT® provides good features such as multimedia, and it can be applied to many types of application. However, its event driven programming style differs from the conventional procedure type programming style commonly used in the plant control system applications.

Toshiba TOSTEEL-NT™ provides platform for conventional procedure type programming on WindowsNT® as well as for event driven programming. This feature makes it possible to add new functions under WindowsNT® to the conventional software properties and to expand the scope of plant control computers.

Software engineers will find many useful macros and utilities presented by TOSTEEL-NT™, without the worry of commands available under WindowsNT®.

It will be great help for them in achieving equalization of software quality, and also in having transportability between different versions of WindowsNT®.

“WindowsNT” is a trademark of the Microsoft Corporation.

FS-1200/800 Banknote Processing Machine for Overseas

Toshiba has developed a banknote processing machine FS-1200/800 for foreign central banks. To respond to the need for processing various styles of banknote, Toshiba has drawn upon its years of experience in the field of banknote processing machines, to develop a machine with simple operation, flexible configuration, and excellent cost performance.

The FS-1200 is targeted for banks that require large volume output, while the FS-800 is targeted for banks requiring medium volume output. The processing speed of the FS-1200 machine is 1200 notes per minute, and 760 notes per minute for the FS-800.

Moreover, the machine is equipped with new detectors that can scan the entire surface area of both sides of the banknotes at this processing speed. Toshiba offers a wide selection of authenticity detection systems. By combining suitable detectors to match the characteristics of banknotes to be processed, the system can be customized for virtually every banknotes issued by a nation.

The machine can be adjusted automatically to the size of the particular banknote. The change of processing denomination from one to another is easy and quick. The machine contains an on-line shredder as standard equipment. Shredder operation can be selected from the graphical user interface (GUI), through the display panel. Because of strong demand from customers, the controls at the display panels are designed to accommodate the use of a preferred language.

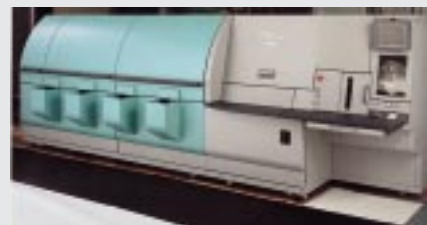

Banknote processing machine FS-1200/800